

NUEVO LATODUE

CIERRE LATERAL AUTOMÁTICO PARA CORREDERAS

Nueva versión con
formas redondeadas

Gama completa

Fijación oculta

Sistema de fijación
reducido y mecanizado
estándar

 SAVIO



ESP 05/2004

Estilo refinado y perfecta maniobrabilidad

NUEVAS FORMAS REDONDEADAS

Confirmando la maniobrabilidad ya conocida, la nueva versión combina mejor con las nuevas series de perfiles de formas redondeadas.

GAMA COMPLETA

Dos versiones, con forma rectangular o redondeada, que utilizan los mismos kit de fijación, los ganchos del cierre 2050 y los contracierres de la gama MODULO. Disponible también la versión totalmente blanca y la versión desmontada (bruto) para colores especiales.

FIJACIÓN OCULTA

Se fija mediante un prisionero premontado, accesible con la leva de maniobra accionada y por lo tanto no visible a simple vista.

Nuevo LATODUE : las formas se redondean

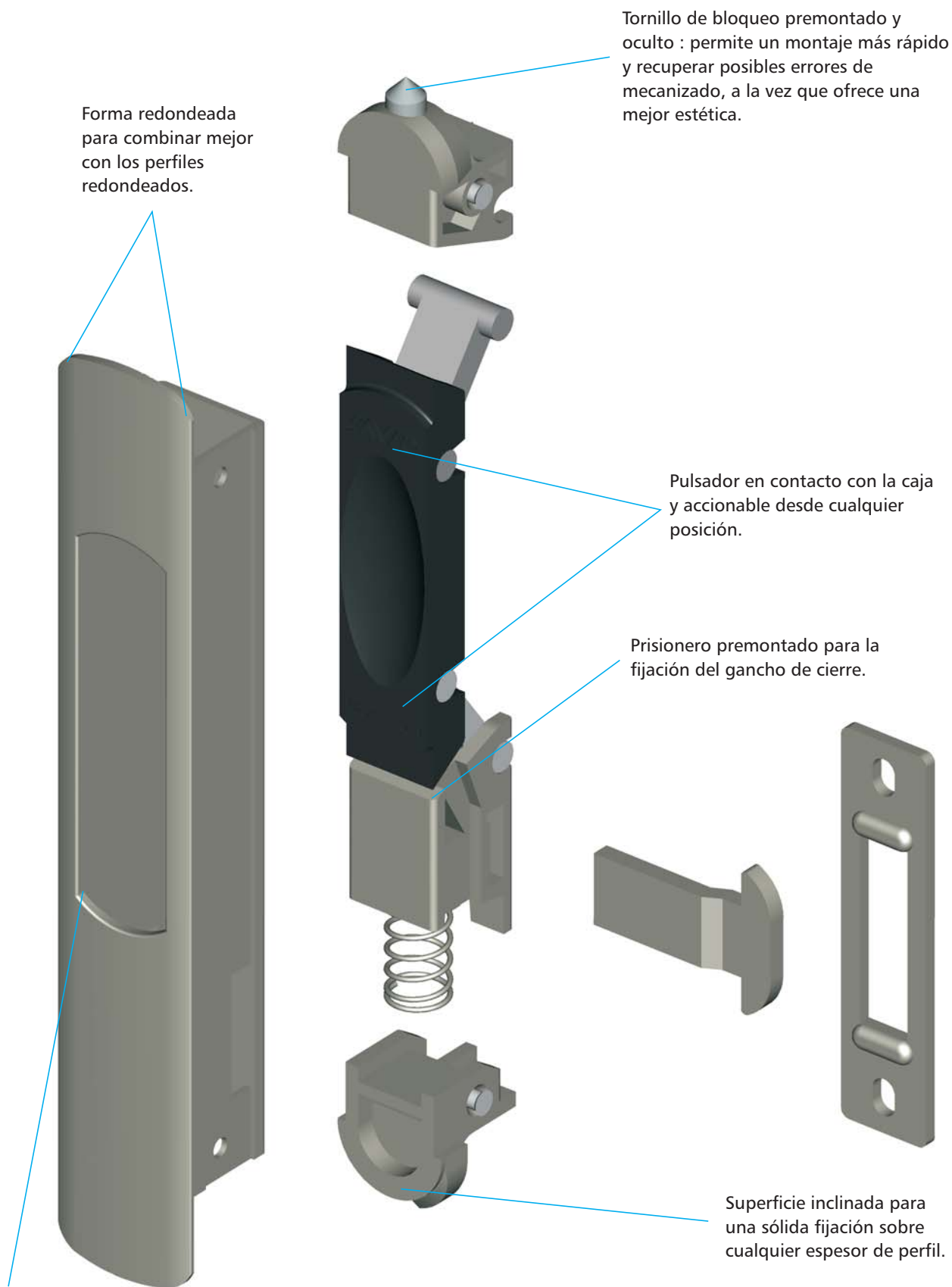

Cierres laterales para correderas

Art.	Descripción	Pz.	Acabados
	2060 (patentado) Cierre lateral para correderas en aluminio extruído, zamac y nylon; prisioneros zincados M6x8 y M6x20, premontados (9010W=con leva en nylon blanco).	20	C, F, NE, ZE, HL, 1013, 1015, 9010, 9010W
	2060.1 (patentado) Cierre lateral redondeada para correderas en aluminio extruído, zamac y nylon; prisioneros zincados M6x8 y M6x20, premontados (9010W=con leva en nylon blanco).	20	C, F, NE, ZE, HL, 1013, 1015, 9010, 9010W
	2060.801 Kit de 1 gancho y 1 contracierre en acero inox 430, 2 tornillos TC Ø 3,9x13 en acero inox 304.	40	
	2060.802 Kit de 1 gancho en acero inox 430, 1 contracierre en zamac zincado negro y 2 tornillos TC Ø 3,9x13 en acero inox 304.	40	
	2060.803 Kit de 1 gancho en acero inox 430, 1 contracierre en zamac zincado negro y 2 tornillos TC Ø 3,9x13 en acero inox 304.	40	
	2060.804 Kit de 1 gancho y 1 contracierre en acero inox 430, 2 tornillos TC Ø 3,9x13 en acero inox 304.	40	
	2050.703 2050.708 Gancho recto en acero inox 430.	40 40	

NUEVO!

NUEVO LATODUE

Accesorios para los cierres LATODUE

	Art.	Descripción	Pz.
	2050.709/.710/.711 2050.712/.713	Gancho curvado en acero inox 430.	40
	2070.860/.863/.864 2070.865/.866/.868	Contracierre en acero inox 430, 2 tornillos TC Ø 3,9x13 en acero inox 304.	40
	2070.861/.867	Contracierre en acero inox 430, 2 tornillos TC Ø 3,9x13 en acero inox 304.	40
	2070.862	Contracierre en zamac zincado negro, 2 tornillos TC Ø 3,9x13 en acero inox 304.	40
	2070.870	Contracierre oculto en zamac zincado negro, 2 tornillos TS Ø 3,9x9,5 en acero inox 304.	40
	2070.869/.875/.876/.877	Contracierre en aluminio negro y prisioneros premontados.	40
	2070.871/.872/.873/.874	Contracierre en zamac zincado negro y prisioneros premontados.	40
	2070.878	Contracierre en zamac zincado negro, 2 tornillos TS Ø 3,9x16 zincados blancos.	40
	2070.879	Contracierre en aluminio negro y prisioneros premontados.	40
	2070.880	Contracierre en acero inox, oculto en zamac zincado negro, 2 tornillos TS M4x12 en acero inox 304.	40

Legenda de los Acabados

1013 = lacado marfil RAL
 1015 = lacado marfil oscuro RAL
 9010 = lacado blanco RAL

9010W = totalmente lacado blanco RAL
 C = bruto
 F = plata anodizada

NE = negro electrocolor
 ZE = café electrocolor
 HL = oro brillante anodizado

Contracrierres serie 2070

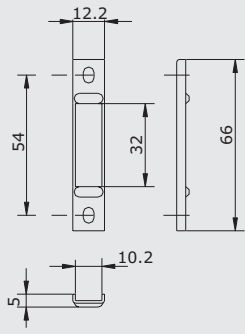

2070.860/.865

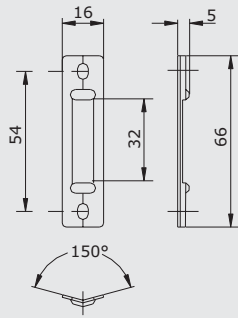

2070.861/.867

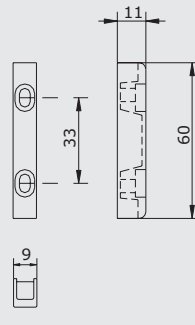

2070.862

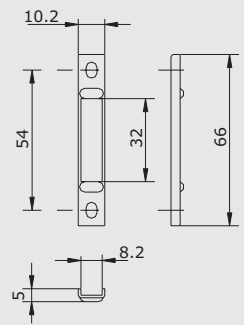

2070.863/.866

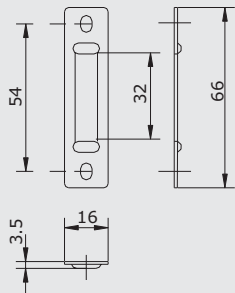

2070.864/.868

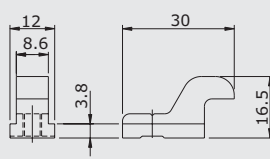

2070.869

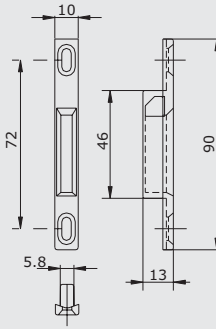

2070.870

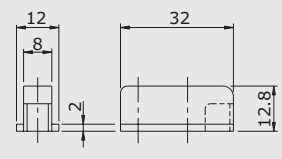

2070.871

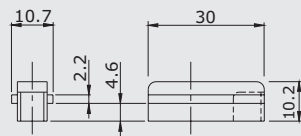

2070.872

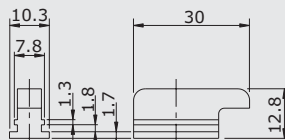

2070.873

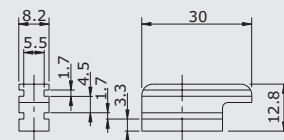

2070.874

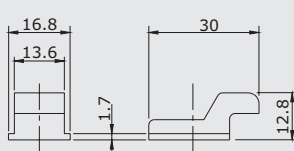

2070.875

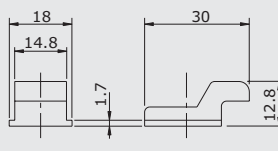

2070.876

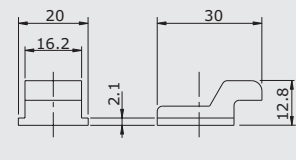

2070.877

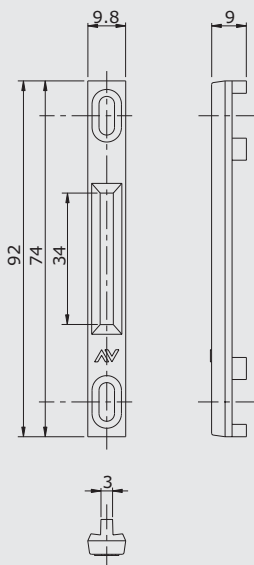

2070.878

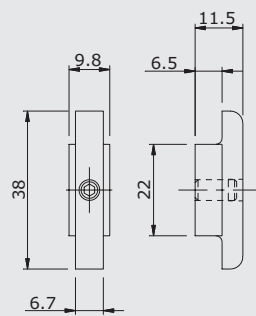

2070.879

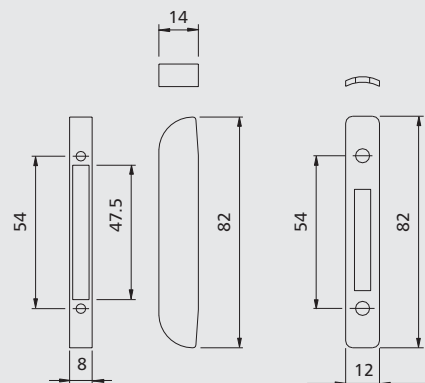

2070.880

Tabla de adaptación para los perfiles italianos

Extrusionador	Perfil	Artículo																					
		2060	2060.1	2060.802	2060.803	2050.703	2050.708	2050.709	2050.710	2050.711	2050.712	2070.860	2070.861	2070.862	2070.863	2070.864	2070.865	2070.867	2070.870	2070.871	2070.875	2070.880	
AL SYSTEM	GLOBAL 60	•	•							•									•				
	RUNNER	•	•							•									•				•
ALCAN	RUNNER 61-90	•	•							•									•				
	RUNNER 61-90 TT	•	•							•									•				
	RUNNER TT	•	•							•									•				
ALCOA	GR 16/80																•						
	GR 16/100																•						
	R 50 S	•	•	•	•	•	•												•				•
	WIN90 S	•	•									•											
	WIN90 S TT	•	•									•											
ALL.CO	EXPORT 60 S	•	•		•														•				
	TRIAL.CO 65 S	•	•									•											
	TRIAL.CO 65 TT	•	•									•											
	TRIAL.CO 90 S	•	•									•											
	TRIAL.CO 90 TT	•	•									•											
ALUMEC	SG 55	•	•								•												•
	ZN 7-32	•	•								•												•
BODEGA	BS 6	•	•						•														
ETA	E 48 S	•	•						•														
	E 48 S TT	•	•						•														
FINAL	EXPORT 65 S	•	•									•											
	EXPORT 65 ST	•	•									•											
HYDRO	DOMAL 40 S	•	•									•								•			
	DOMAL SLIDE 110	•	•							•												•	•
	DOMAL SLIDE 56	•	•									•								•			•
	DOMAL SLIDE 84	•	•									•											
	DOMAL SLIDE PA	•	•									•											
	DOMAL SLIDE PA 110	•	•							•												•	
	DOMAL SLIDE PA 80	•	•						•														
IND.INVEST	ALPHA 186	•	•																				•
	ALPHA 545 S	•	•									•											•
	ALPHA 560 S	•	•		•																		•
	GOLD 650 S	•	•									•											•
	GOLD 650 ST	•	•									•											•
METRA	NC 50 S	•	•							•													
	NC 60 INT.	•	•									•											
	NC 60 STH	•	•									•											•
	NC 70 S	•	•									•											
	NC 90 INT.	•	•									•										•	
	NC 90 S	•	•									•											
	NC 90 STH	•	•									•											•
MORELLI	MA 8700	•	•									•											•
OCMA	MONACO	•	•									•											•
	PARIGI	•	•																				•
PASSERINI	SKEIT 45	•	•																				
	SKEIT 60	•	•									•											
	SKEIT 60 SUPER	•	•									•											
	SKEIT 60 SUPER TT	•	•									•											
	SKEIT 70	•	•									•											
	SKEIT 70 THERMO	•	•									•											
	SKEIT 80	•	•		•																		
	SKEIT 90	•	•									•											•
PONZIO SUD	NEW TEC 80 S	•	•									•											•
	NEW TEC 90 S TT	•	•									•											•
	SLIDING 600																						
	SLIDING 900																						
	SLIDING 900 TT																						
PROFILATI	PE 60 SLIDE	•	•																				•
	PE 70 SLIDE	•	•																				
	PE 70 SLIDE TT	•	•																				
	TE 640 S	•	•		•																		
SCHUCO	ROYAL 110	•	•																				
	ROYAL 110 ISO	•	•																				
	ROYAL S 20N	•	•																				

SAVIO S.p.A. se reserva el derecho de cambiar en cualquier momento y sin previo aviso las características técnicas de los productos presentados dentro de este catálogo.

9507.429 - REV. 0 - 229044