

NOUVELLE LATODUE

FERMETURE LATÉRALE AUTOMATIQUE POUR COULISSANT

Nouvelle version avec
formes arrondies

Gamme complète

Fixation invisible

Encombres réduits
et usinage standard

 SAVIO



FR 05/2004

Design raffiné et manoeuvrabilité optimale

NOUVEAU DESIGN ARRONDI

En conservant la manoeuvrabilité bien connue, la nouvelle version s'adapte mieux aux nouvelles séries de profilés avec forme arrondies.

GAMME COMPLETE

Les deux versions, standard ou avec formes arrondies, utilisent les mêmes kits de fixation, tous les pènes de la gamme des fermeture 2050 et les gâches de la gamme MODULO.

Disponibilité de la finition complètement blanche et de la version non montée pour laquage en finitions spéciales.

FIXATION INVISIBLE

Elle est fixée à l'aide d'une vis-pointeau prémontée, accessible à verrou ouvert et par conséquent invisible normalement.

Nouvelle LATODUE : les formes s'adoucissent

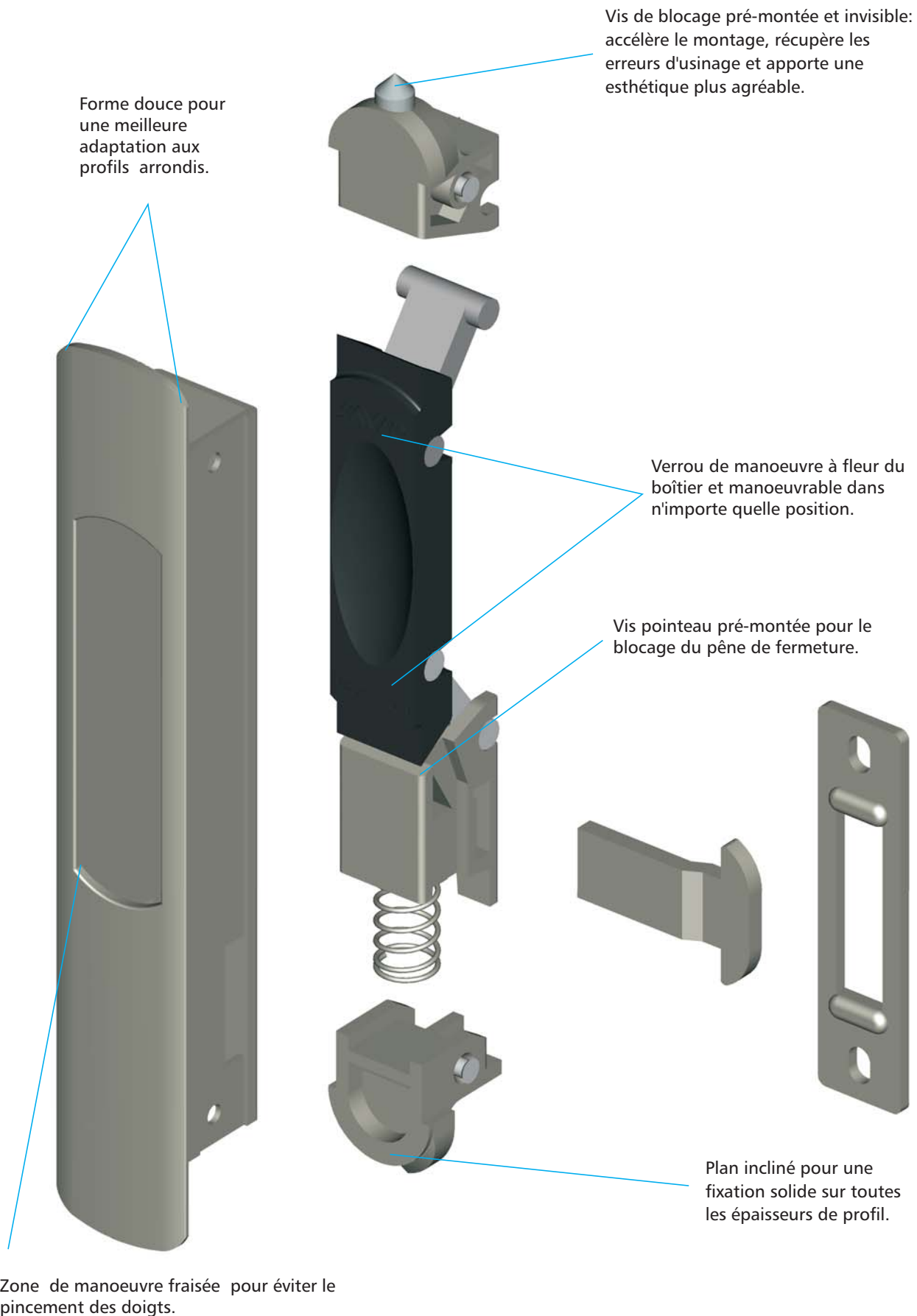

Fermatures latérales et accessoires pour coulissant

Art.	Description	Pz.	Finitions
	2060 (breveté) Fermeture latérale pour coulissant en aluminium extrudé, zamack et nylon; vis pointeaux zinguées M6x8 et M6x20, pré-assemblées (9010W=avec cuvette en nylon blanc).	20	C, F, NE, ZE, HL, 1013, 1015, 9010, 9010W
	2060.1 (breveté) Fermeture latérale arrondie pour coulissant, en aluminium extrudé, zamack et nylon; vis pointeaux zinguées (M6x8 et M6x20) et pré-assemblées (9010W=avec cuvette en nylon blanc).	20	C, F, NE, ZE, HL, 1013, 1015, 9010, 9010W
	2060.801 Kit de 1 pêne et 1 gâche en acier inox 430, 2 vis TC Ø 3,9x13 en acier inox 304.	40	
	2060.802 Kit de 1 pêne en acier inox 430, 1 gâche en zamack zingué noir et 2 vis TC Ø 3,9x13 en acier inox 304.	40	
	2060.803 Kit de 1 pêne en acier inox 430, 1 gâche en zamack zingué noir et 2 vis TC Ø 3,9x13 en acier inox 304.	40	
	2060.804 Kit de 1 pêne et 1 gâche en acier inox 430, 2 vis TC Ø 3,9x13 en acier inox 304.	40	
	2050.703 2050.708 Pêne droit en acier inox 430.	40 40	

NOUVEAUTE!

Accessoires pour les fermetures LATODUE

	Art.	Description	Pz.
	2050.709/.710/.711 2050.712/.713	Pêne contrecoudé en acier inox 430.	40 40
	2070.860/.863/.864 2070.865/.866/.868	Gâche en acier inox 430, 2 vis TC Ø 3,9x13 en acier inox 304.	40 40
	2070.861/.867	Gâche en acier inox 430, 2 vis TC Ø 3,9x13 en acier inox 304.	40
	2070.862	Gâche en zamack zingué noir, 2 vis TC Ø 3,9x13 en acier inox 304.	40
	2070.870	Gâche à visser en zamack zingué noir, 2 vis TF Ø 3,9x9,5 en acier inox 304.	40
	2070.869/.875/.876/.877	Gâche en aluminium noir et vis pointeau pré-assemblées.	40
	2070.871/.872/.873/.874	Gâche en zamack zingué noir et vis pointeau pré-assemblées.	40
	2070.878	Gâche en zamack zingué noir, 2 vis TF Ø 3,9x16 zinguées blanches.	40
	2070.879	Gâche en aluminium noir et vis pointeau pré-assemblées.	40
	2070.880	Gâche en acier inox, à visser en zamack zingué noir, 2 vis TF M4x12 en acier inox 304.	40

Légende des finitions

1013 =	laqué ivoire RAL	9010W =	complètement laquée blanche RAL	NE =	anodisé noir électrocoloré
1015 =	laqué ivoire foncé RAL	C =	brut	ZE =	anodisé bronze électrocoloré
9010 =	laqué blanc RAL	F =	anodisé naturel	HL =	or poli

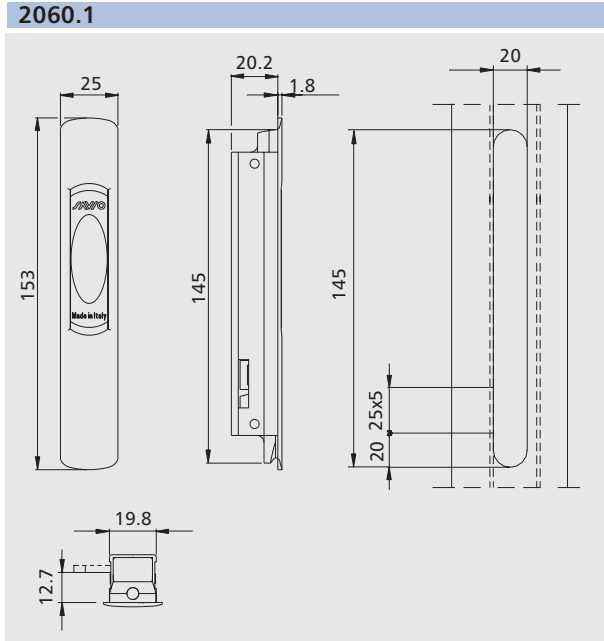
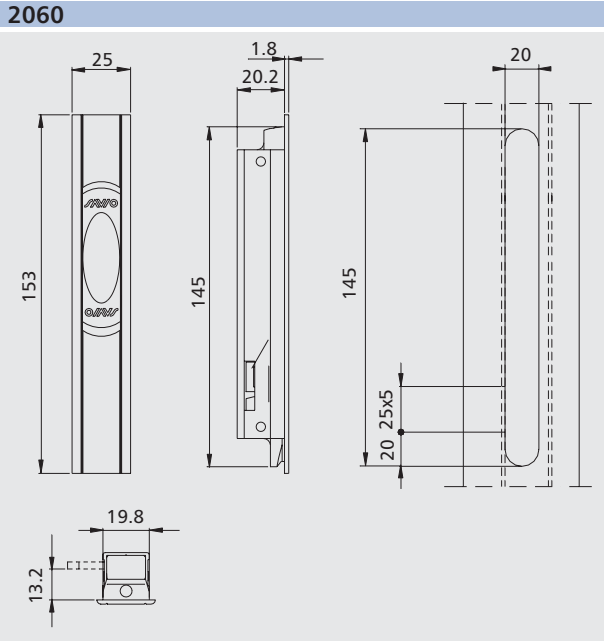

2060.801/.802/.803/.804

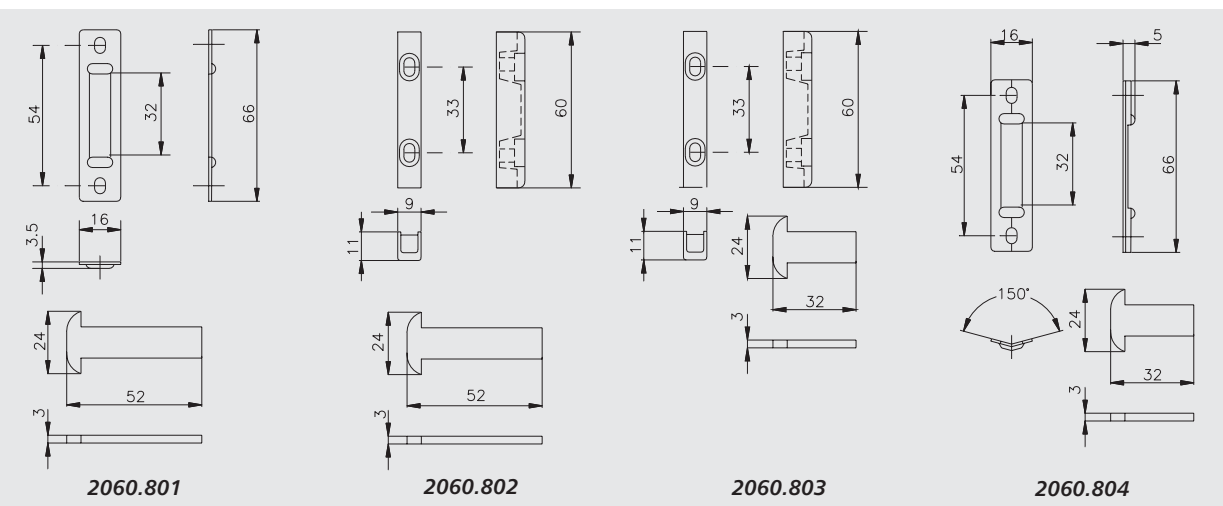

2050.703/.708/.709/.710/.711/.712/.713

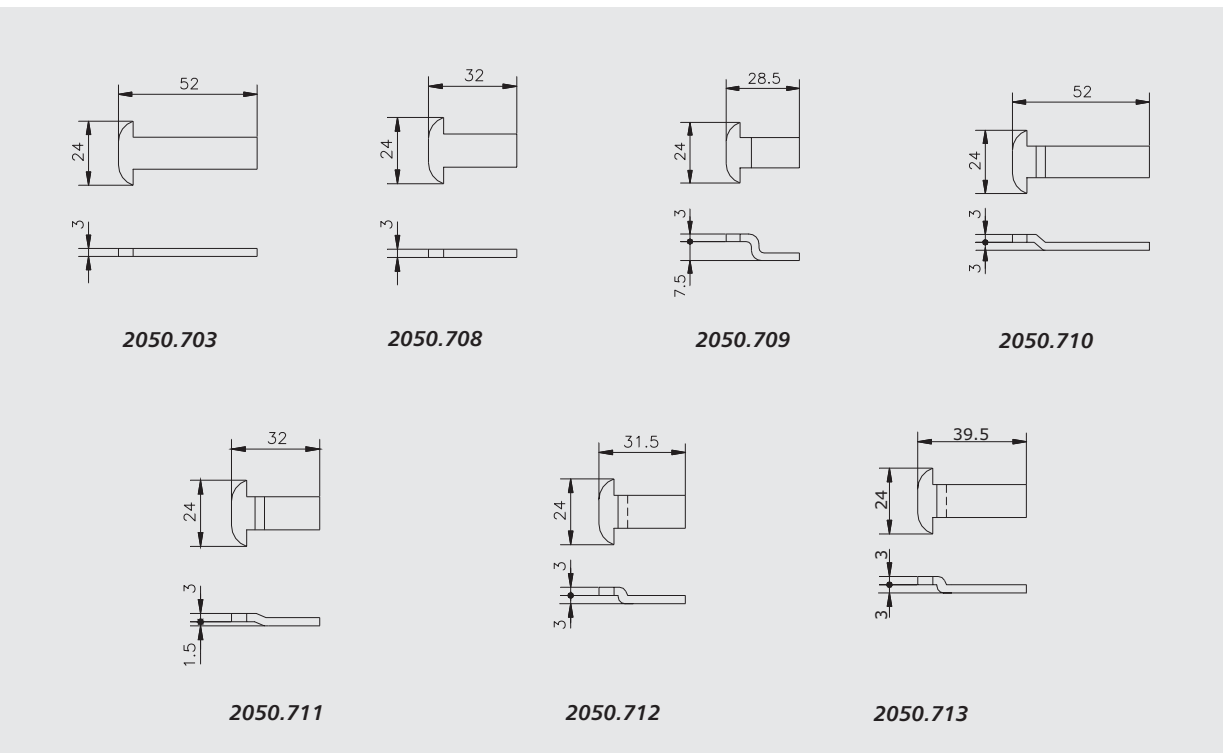

Gâches série 2070

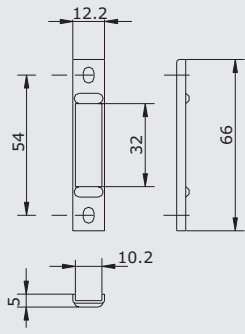

2070.860/.865

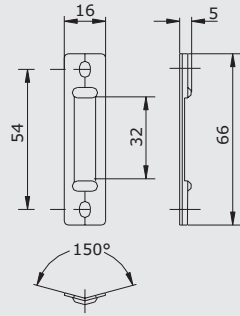

2070.861/.867

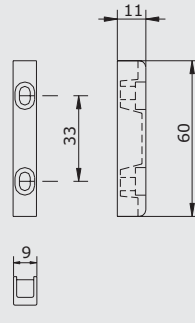

2070.862

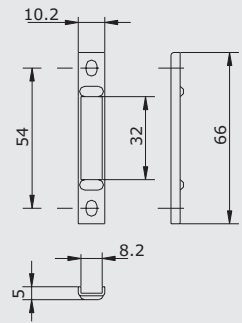

2070.863/.866

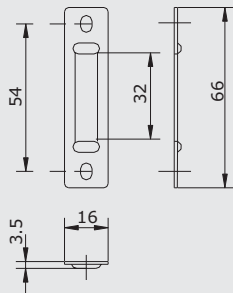

2070.864/.868

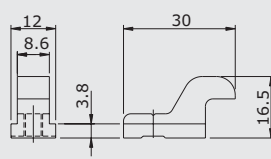

2070.869

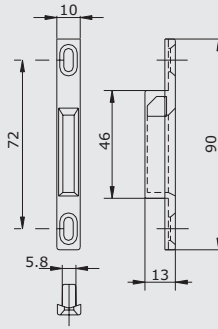

2070.870

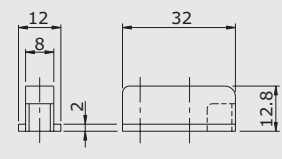

2070.871

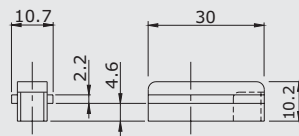

2070.872

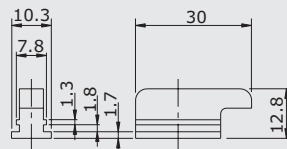

2070.873

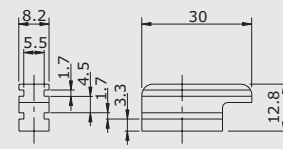

2070.874

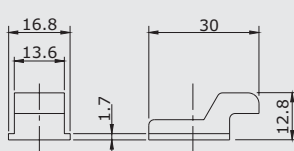

2070.875

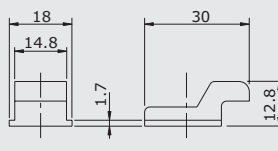

2070.876

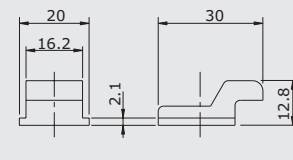

2070.877

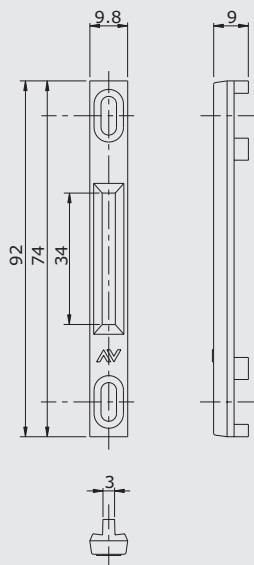

2070.878

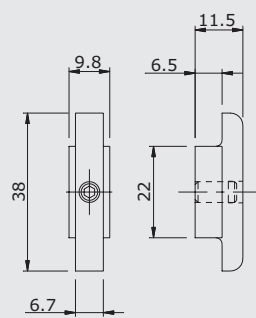

2070.879

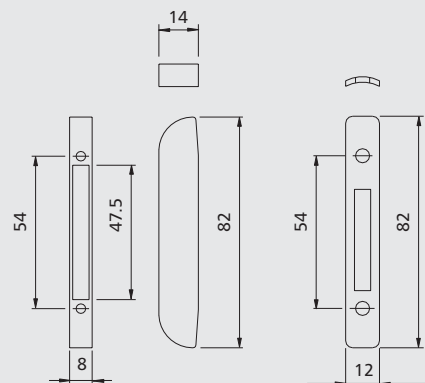

2070.880

Fiche d'adaptation aux profils italiens

Gammiste	Profil	Article																					
		2060	2060.1	2060.802	2060.803	2050.703	2050.708	2050.709	2050.710	2050.711	2050.712	2070.860	2070.861	2070.862	2070.863	2070.864	2070.865	2070.867	2070.870	2070.871	2070.875	2070.880	
AL SYSTEM	GLOBAL 60	•	•							•									•				
ALCAN	RUNNER	•	•							•				•					•				•
	RUNNER 61-90	•	•							•				•					•				
	RUNNER 61-90 TT	•	•							•				•					•				
ALCOA	RUNNER TT	•	•							•				•					•				
	R 50 S	•	•	•	•	•	•							•					•				•
	WIN90 S	•	•											•					•				
ALL.CO	WIN90 S TT	•	•											•					•				
	EXPORT 60 S	•	•		•									•					•				
	TRIAL.CO 65 S	•	•											•					•				
	TRIAL.CO 65 TT	•	•											•					•				
ALUMEC	TRIAL.CO 90 S	•	•											•					•				
	TRIAL.CO 90 TT	•	•											•					•				
BODEGA	SG 55	•	•																•			•	
ETA	ZN 7-32	•	•																•			•	
	BS 6	•	•							•									•				
FINAL	E 48 S	•	•											•					•				
	E 48 S TT	•	•											•					•				
HYDRO	EXPORT 65 S	•	•											•					•				
	EXPORT 65 ST	•	•											•					•				
IND.INVEST	DOMAL 40 S	•	•											•					•				
	DOMAL SLIDE 110	•	•							•									•			•	
	DOMAL SLIDE 56	•	•																•				•
	DOMAL SLIDE 84	•	•																•				
	DOMAL SLIDE PA	•	•																•				
	DOMAL SLIDE PA 110	•	•							•									•			•	
METRA	DOMAL SLIDE PA 80	•	•						•					•					•				
	ALPHA 186	•	•																•				•
	ALPHA 545 S	•	•																•				•
	ALPHA 560 S	•	•		•														•				•
	GOLD 650 S	•	•																•				
PASSERINI	GOLD 650 ST	•	•																•				
	NC 50 S	•	•							•						•			•				•
	NC 60 INT.	•	•								•				•				•				
	NC 60 STH	•	•								•				•				•				
	NC 70 S	•	•								•				•				•			•	
	NC 90 INT.	•	•								•				•				•				
	NC 90 S	•	•								•				•				•				
PONZIO SUD	NC 90 STH	•	•											•					•				
	MA 8700	•	•																•				
SCHUCO	MONACO	•	•																•				
	PARIGI	•	•							•									•				
PROFILATI	SKEIT 60	•	•																•				
	SKEIT 60 SUPER	•	•																•				
	SKEIT 60 SUPER TT	•	•																•				
	SKEIT 70	•	•								•				•				•				
	SKEIT 70 THERMO	•	•																•				
	SKEIT 80	•	•		•										•				•				
SCHUCO	SKEIT 90	•	•																•				•
	NEW TEC 80 S	•	•																•				•
	NEW TEC 90 S TT	•	•																•				•
SCHUCO	PE 60 SLIDE	•	•																•				•
	PE 70 SLIDE	•	•																•				•
	PE 70 SLIDE TT	•	•																•				•
SCHUCO	TE 640 S	•	•		•				•										•				
	ROYAL 110	•	•							•									•				
SCHUCO	ROYAL 110 ISO	•	•							•									•				
	ROYAL 110 ISO	•	•							•									•				

SAVIO S.p.A. se réserve la possibilité de modifier à tout moment et sans préavis les caractéristiques techniques des produits présentés dans ce catalogue.

9507.430 - REV. 0 - 217054

NOUVELLE LATO DUE