

FASTENING KITS

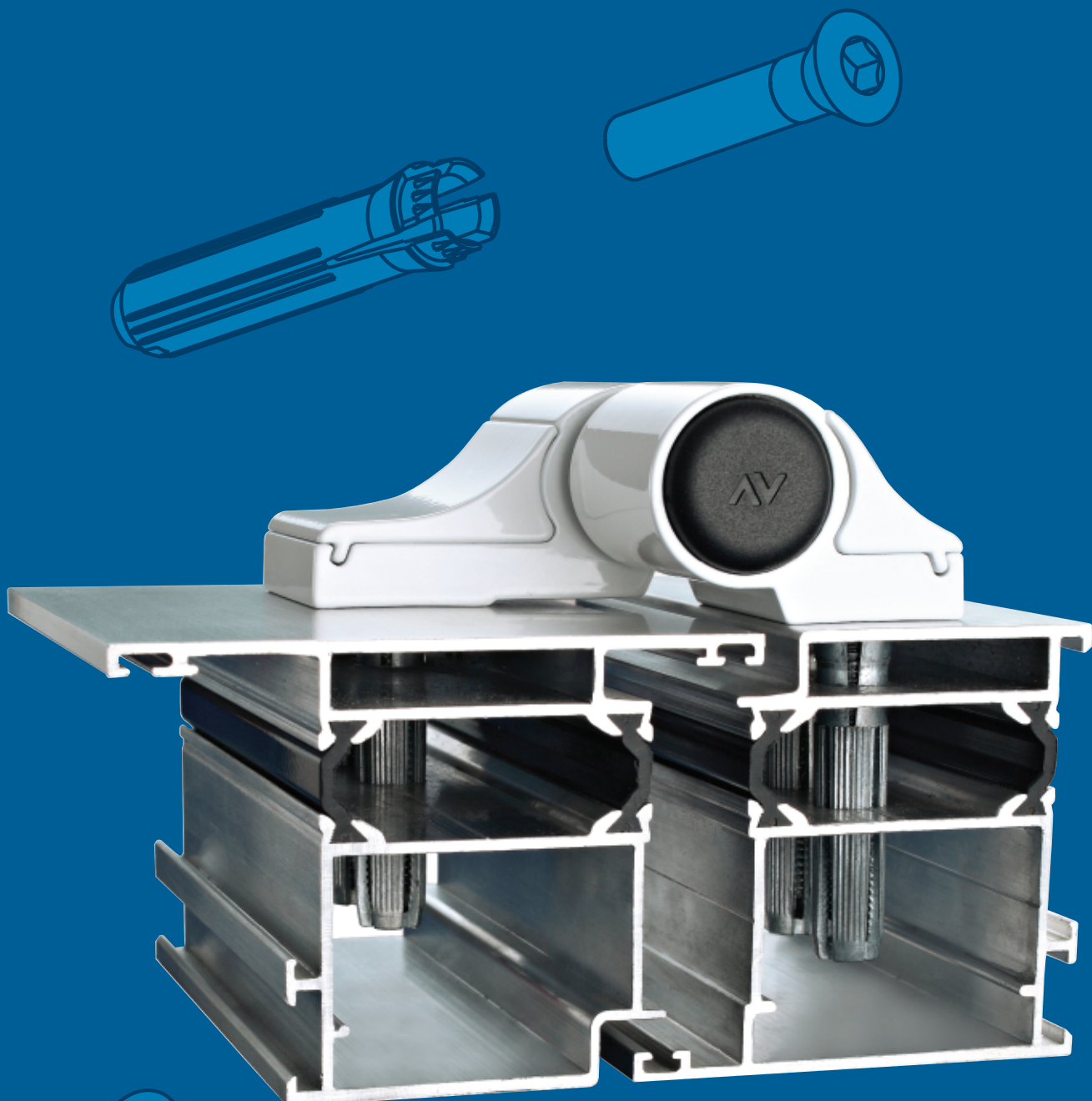

SCREW ANCHORS FASTENING KITS FOR 2-WING
AND 3-WING MECHANICA HINGES

GB 02/2007

AV SAVIO

General features

FASTENING KITS

EASY AND FAST APPLICATION

Easy and fast application thanks to an assembling tool and an only drilling of Ø11 mm.

CAN BE APPLIED ON DOORS ALREADY INSTALLED

The frontal assembly of the screw anchors permits to replace or add hinges on doors already installed.

SOLUTIONS FOR ANY APPLICATIONS

The different available versions permit the use of these screw anchors both on external and internal openings.

AVAILABLE WITH MECHANICAL STANDARD HINGES

It is possible to combine the screw anchors to MKD hinges (1145) and MKW (1146) excluding 1145/53-1145/60MR-1145/67MR-1145.3/53 versions.

AVAILABLE FOR THERMAL BREAK AND NON-THERMAL BREAK PROFILES

Wide range and different sizes allow the application on thermal break and non-thermal break profiles.

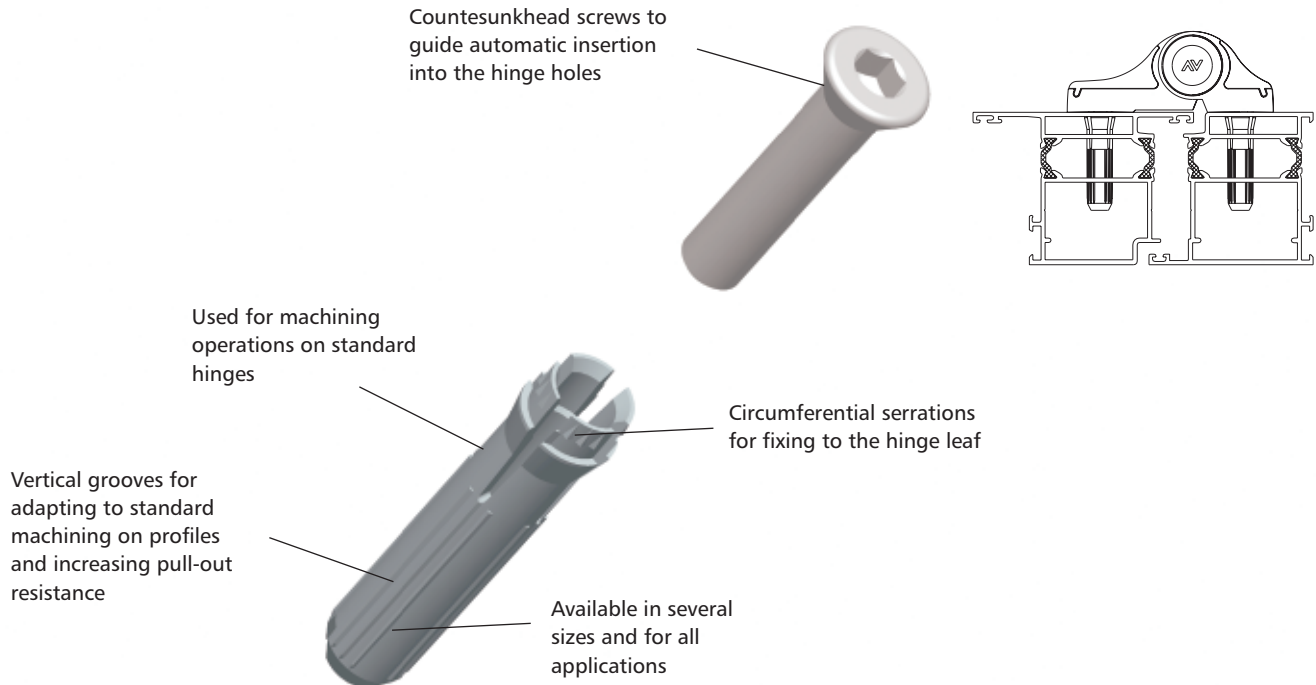

New fixing kit for thermal break profiles

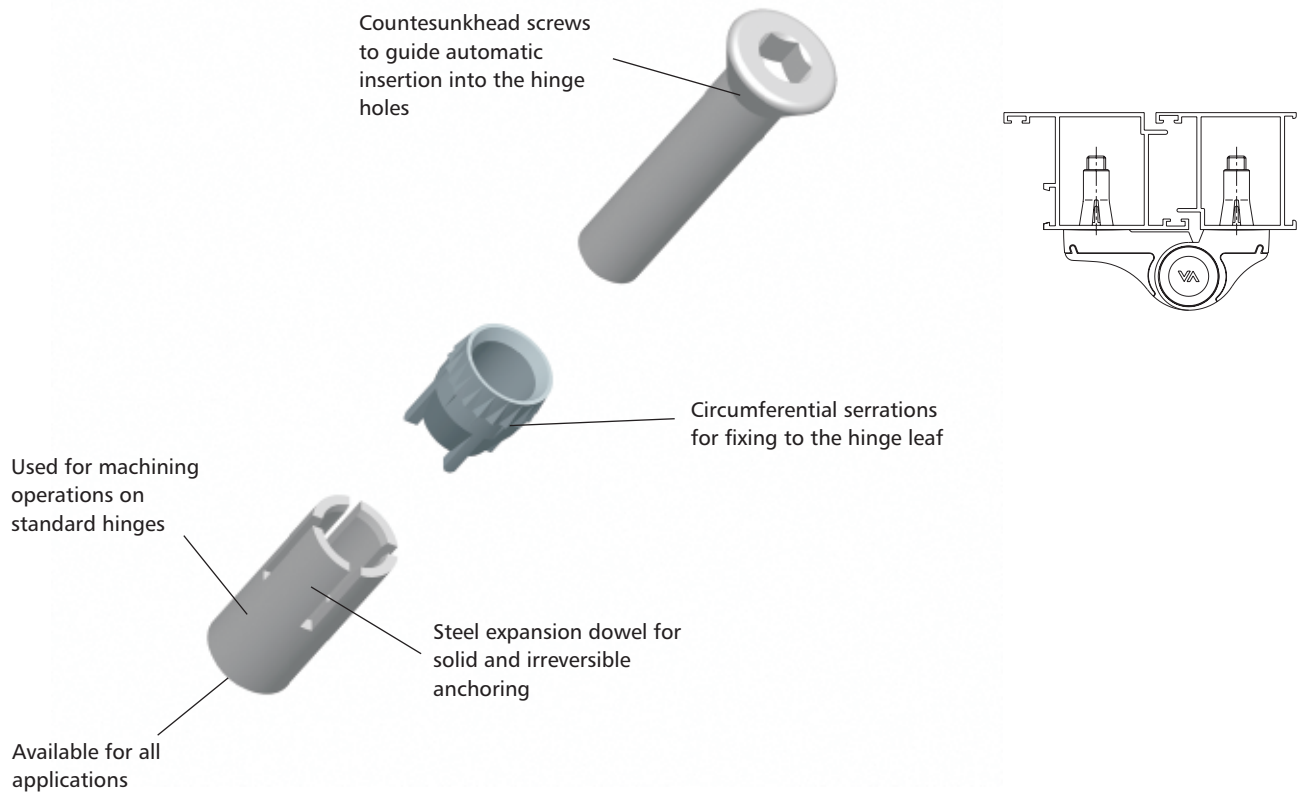

New fixing kit for non-thermal break profiles



FASTENING KITS

Fastening Kits			
Art.	Description	Pz.	
	1145.720 (patented) Fastening kit for 2-wing MECHANICA hinges including: 4 zamak inserts of 40 mm, 4 galvanized special screws M8x40 and 2 galvanized socket head cap screws M4x16 for cover fastening, 1 galvanized grub screw M6x8 for cam bushing fastening. <i>Package: 10 bags including 2 complete kits.</i>	20	
	1145.722 (patented) Fastening kit for 3-wing MECHANICA hinges including: 6 zamak inserts of 40 mm, 6 galvanized special screws M8x40 and 3 galvanized socket head cap screws M4x16 for cover fastening, 1 galvanized grub screw M6x8 for cam bushing fastening. <i>Package: 5 bags including 2 complete kits.</i>	10	
	1145.724 (patented) Fastening kit for 2-wing MECHANICA hinges including: 4 zamak inserts of 50 mm, 4 galvanized special screws M8x40 and 2 galvanized socket head cap screws M4x16 for cover fastening, 1 galvanized grub screw M6x8 for cam bushing fastening. <i>Package: 10 bags including 2 complete kits.</i>	20	
	1145.726 (patented) Fastening kit for 3-wing MECHANICA hinges including: 6 zamak inserts of 50 mm, 6 galvanized special screws M8x40 and 3 galvanized socket head cap screws M4x16 for cover fastening, 1 galvanized grub screw M6x8 for cam bushing fastening. <i>Package: 5 bags including 2 complete kits.</i>	10	
	1145.728 (patented) Fastening kit for 2-wing MECHANICA hinges including: 4 zamak inserts and 4 galvanized inserts, 4 galvanized special screws M8x40 and 2 galvanized socket head cap screws M4x16 for cover fastening, 1 galvanized grub screw M6x8 for cam bushing fastening. <i>Package: 10 bags including 2 complete kits.</i>	20	
	1145.729 (patented) Fastening kit for 3-wing MECHANICA hinges including: 6 zamak inserts and 6 galvanized inserts, 6 galvanized special screws M8x40 and 3 galvanized socket head cap screws M4x16 for cover fastening, 1 galvanized grub screw M6x8 for cam bushing fastening. <i>Package: 5 bags including 2 complete kits.</i>	10	
	1145.900 Nylon assembling tool for MECHANICA fixing devices art. 1145.720 - 1145.722 - 1145.724 - 1145.726.	4	

Schemes and suitability

Series of screw anchors for thermal break profiles

1145.720

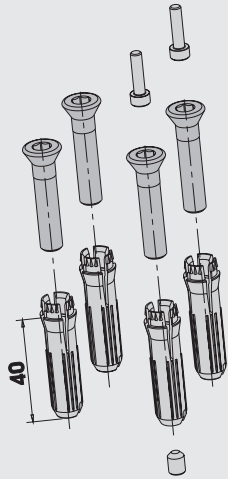

1145.724

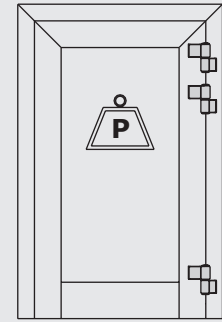
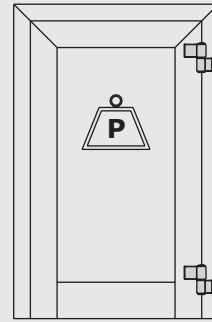
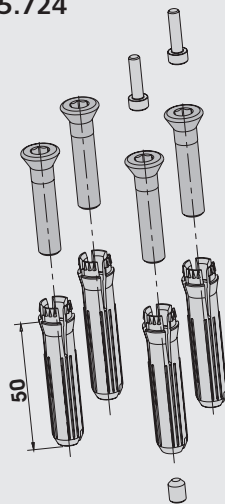

Art.		P
1145/60	1145/67	80 Kg
1146/59	1146/62,5	
1146/67	1146.2/62	
1145/79	1145/86	60 Kg
1145/93	1145/93SM	
1146/74,5	1146/78	
1146/84	1146/89	
1146/92	1146/97	
1146/104	1146.1/62,5	
1146.1/84		

Art.		P
1145/60	1145/67	90 Kg
1146/59	1146/62,5	
1146/67	1146.2/62	
1145/79	1145/86	70 Kg
1145/93	1145/93SM	
1146/74,5	1146/78	
1146/84	1146/89	
1146/92	1146/97	
1146/104	1146.1/62,5	
1146.1/84		

1145.722

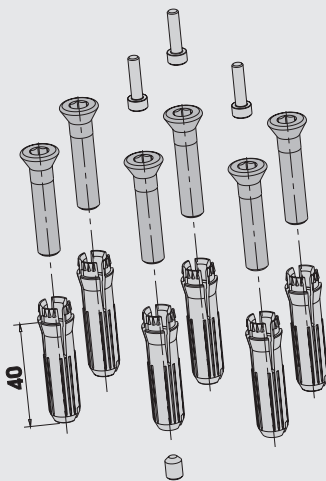

1145.726

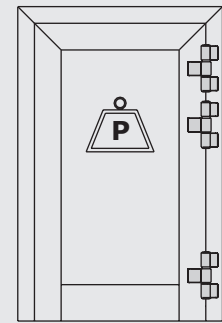
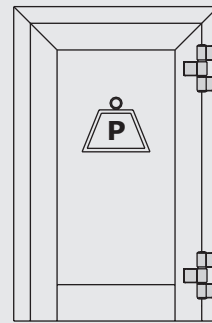
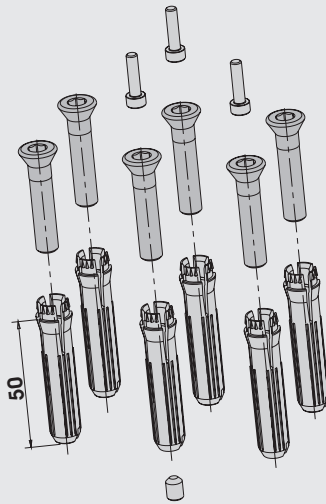

Art.		P
1145.3/60	1145.3/67	80 Kg
1146.3/59	1146.3/62,5	
1146.3/67	1146.23/62	
1145.3/79	1145.3/93	60 Kg
1145.3/93SM		
1146.3/74,5	1146.3/78	
1146.3/84	1146.3/89	
1146.3/92	1146.3/97	
1146.3/104	1146.13/62,5	
1146.13/84		

Art.		P
1145.3/60	1145.3/67	90 Kg
1146.3/59	1146.3/62,5	
1146.3/67	1146.23/62	
1145.3/79	1145.3/93	70 Kg
1145.3/93SM		
1146.3/74,5	1146.3/78	
1146.3/84	1146.3/89	
1146.3/92	1146.3/97	
1146.3/104	1146.13/62,5	
1146.13/84		

1145./..

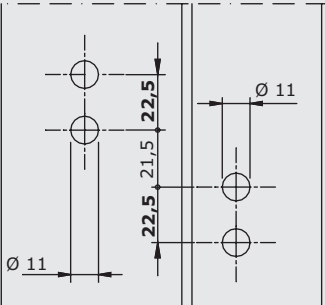

1146./..

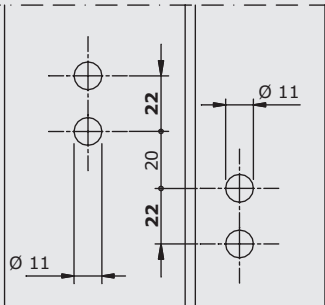

External openings

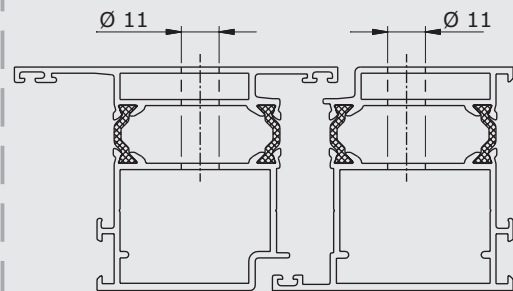

1145.3./..

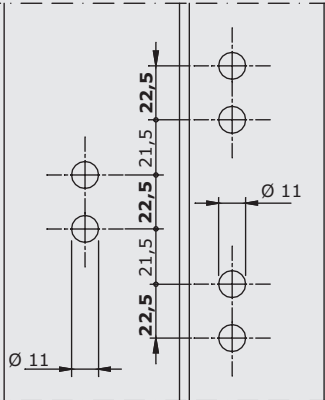

1146.3./..

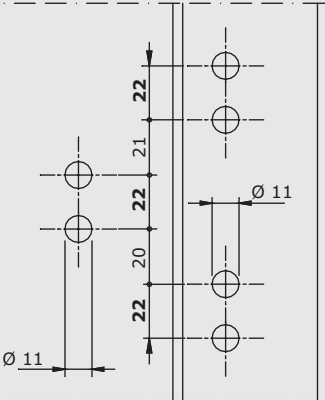

Internal openings

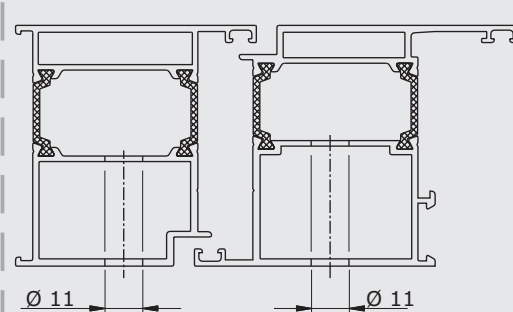

Schemes and suitability

Series of screw anchors for thermal break profiles

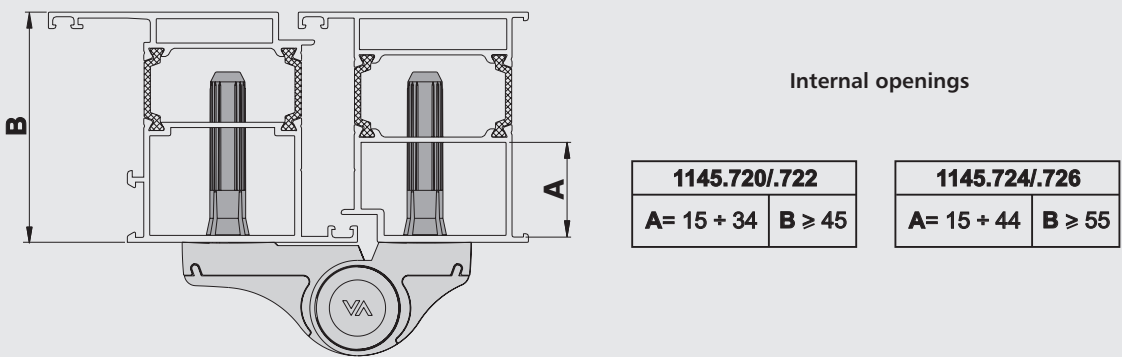
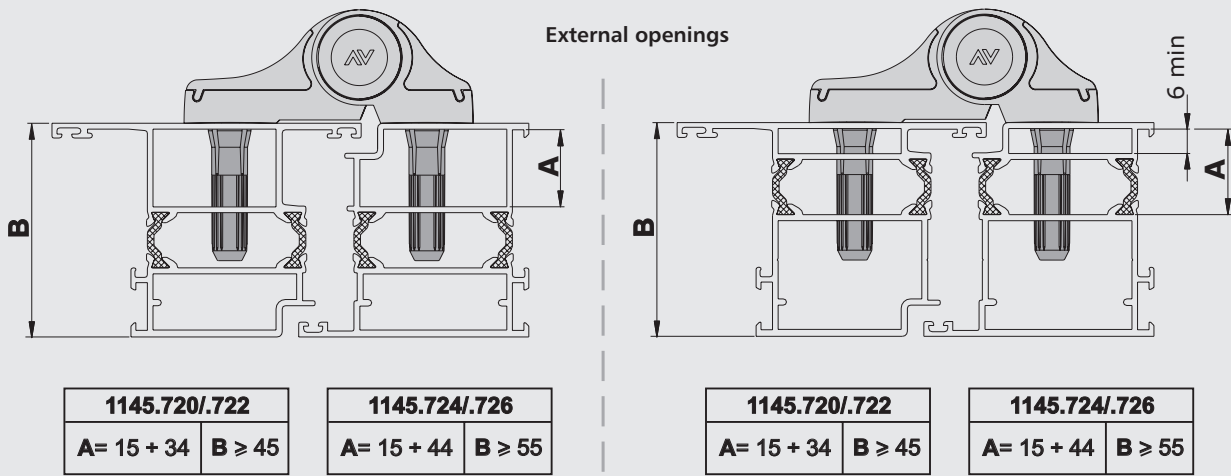

Screw anchors cannot be used in the following cases:

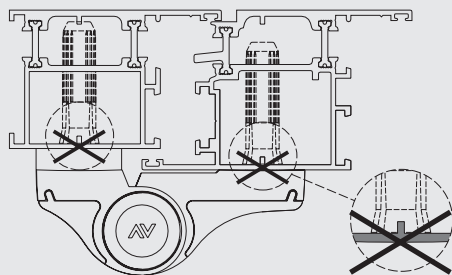
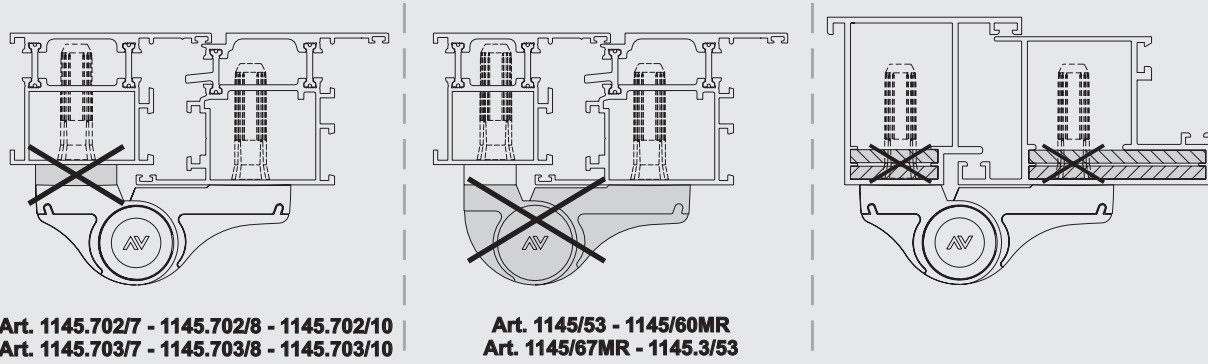

Next to the profiles stiffening ribs

Series of screw anchors for non-thermal break profiles

1145.728

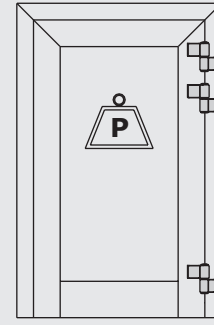
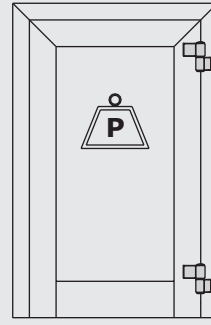
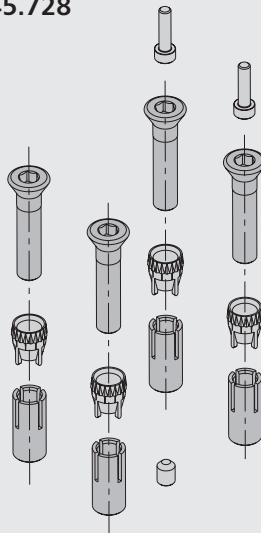

Art.		P
1145/60	1145/67	80 Kg
1146/59	1146/62,5	
1146/67	1146.2/62	
1145/79	1145/86	60 Kg
1145/93	1145/93SM	
1146/74,5	1146/78	
1146/84	1146/89	
1146/92	1146/97	
1146/104	1146.1/62,5	
1146.1/84		

Art.		P
1145/60	1145/67	90 Kg
1146/59	1146/62,5	
1146/67	1146.2/62	
1145/79	1145/86	70 Kg
1145/93	1145/93SM	
1146/74,5	1146/78	
1146/84	1146/89	
1146/92	1146/97	
1146/104	1146.1/62,5	
1146.1/84		

1145.729

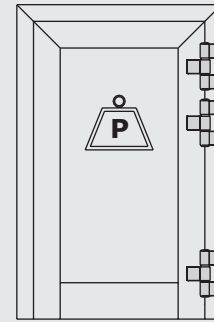
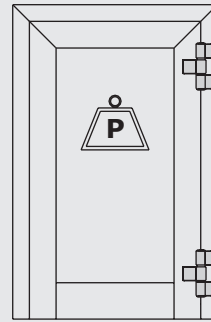
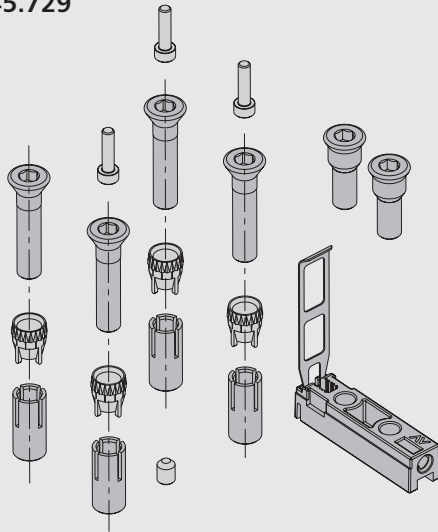

Art.		P
1145.3/60	1145.3/67	80 Kg
1146.3/59	1146.3/62,5	
1146.3/67	1146.23/62	
1145.3/79	1145.3/93	60 Kg
1145.3/93SM		
1146.3/74,5	1146.3/78	
1146.3/84	1146.3/89	
1146.3/92	1146.3/97	
1146.3/104	1146.13/62,5	
1146.13/84		

Art.		P
1145.3/60	1145.3/67	90 Kg
1146.3/59	1146.3/62,5	
1146.3/67	1146.23/62	
1145.3/79	1145.3/93	70 Kg
1145.3/93SM		
1146.3/74,5	1146.3/78	
1146.3/84	1146.3/89	
1146.3/92	1146.3/97	
1146.3/104	1146.13/62,5	
1146.13/84		

1145/..

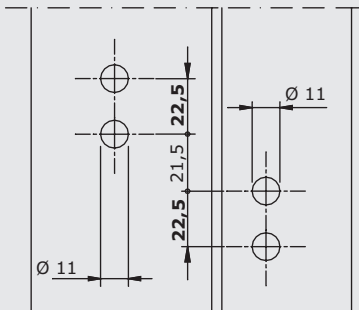

1146/..

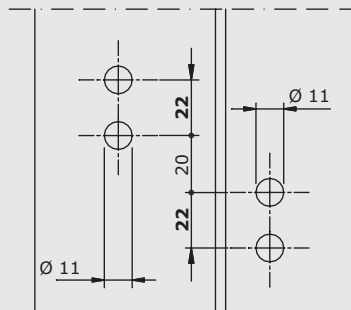

External openings

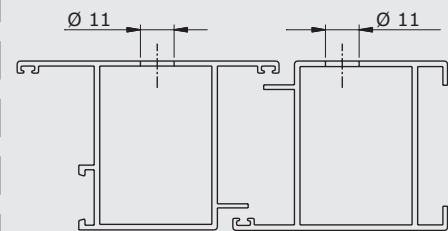

1145.3/..

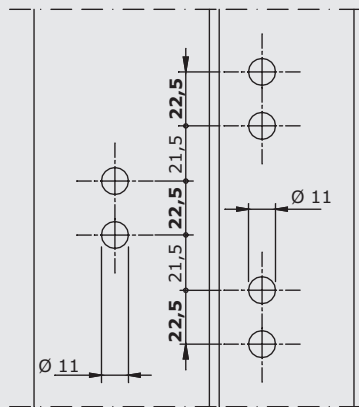

1146.3/..

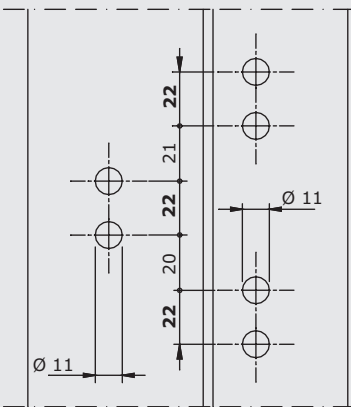

Internal openings

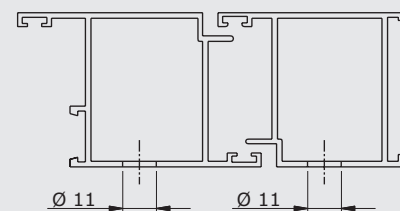

Schemes and suitability

Series of screw anchors for non thermal break profiles

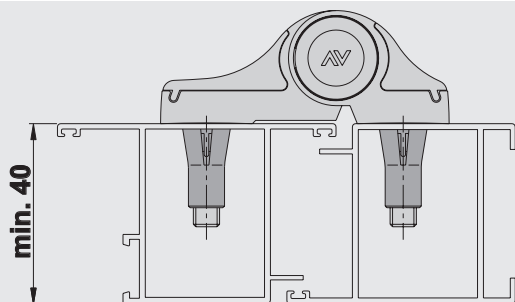

External openings

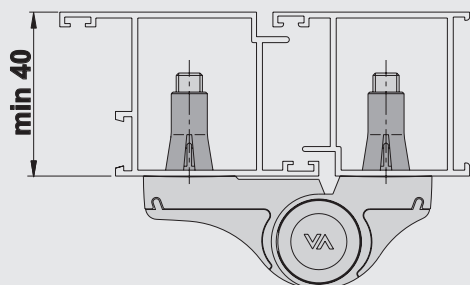

Internal openings

Fixing devices cannot be used in the following cases:

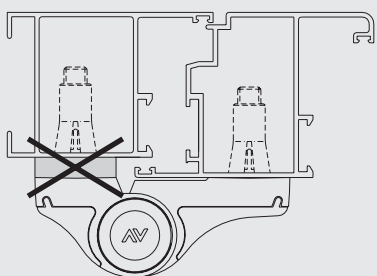

Art. 1145.702/7 - 1145.702/8 - 1145.702/10
Art. 1145.703/7 - 1145.703/8 - 1145.703/10

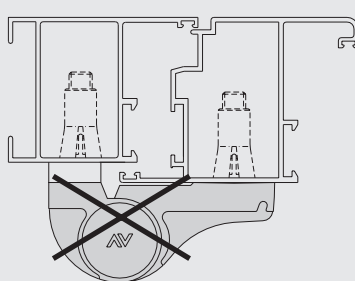

Art. 1145/53 - 1145/60MR
Art. 1145/67MR - 1145.3/53

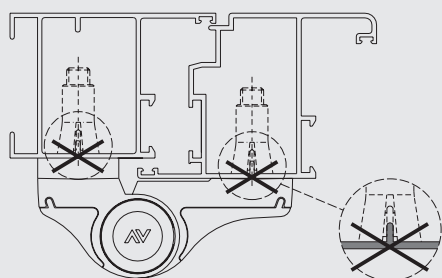
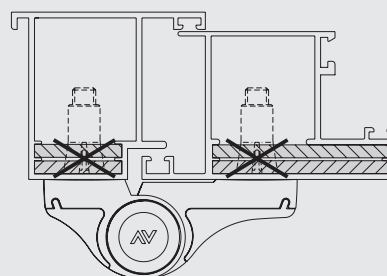

Next to the profiles stiffening ribs



- DIN EN ISO 14001
- Certified Management System
- DIN EN ISO 9001

Savio S.p.A. Via Torino, 25 (S.S. 25)
10050 Chiusa S. Michele (TO) Italy
Tel. +39.011.964.34.64 - Fax +39.011.964.34.74
www.savio.it - e-mail: export@savio.it

AV SAVIO
*Quality and innovation
for closing systems*

9507.556 - REV. 0 - 219027

FASTENING KITS