

Estrusore Extruder	Profilo Profile	① (*)	② (*)	T
ABITHAL SERVICE	GREEN 45 SORMONTO	825.721	825.721	45
ALL.CO	ALCOTEC 72	825.722	825.722	49
ALL.CO	EXPORT 45	825.722	825.722	43
ALL.CO	EXPORT 45 TT	825.722	825.722	43
ALL.CO	EXPORT 50	825.722	825.722	43
ALL.CO	EXPORT 50 TT	825.722	825.722	43
ALL.CO	EXPORT 51 TT	825.722	825.722	43
ALL.CO	EXPORT 68 TT	825.722	825.722	43
ALL.CO	K 40	825.722	825.722	44
ALLU SISTEMI	CX 600	825.722	1243.721	45
ALLU SISTEMI	CX 700	825.722	1243.721	45
ALSISTEM	PLANET 45	825.722	1243.721	45
ALSISTEM	PLANET 62TT	825.722	1243.721	46
ETA	ROAD 520 TT CE	825.722	1243.721	46
ETA	ROAD 600 TT CE	825.722	1243.721	46
ETA	START 410	825.722	1243.721	46
ETA	START 560 TT	825.722	1243.721	45
GEAL	HF 580	825.722	1243.721	46
GEAL	HP 600	825.722	1243.721	46
GEAL	HP 700	825.722	1243.721	46
HYDRO	BREAK PA 52	825.721	825.721	46
HYDRO	BREAK PA 63	825.721	825.721	46
HYDRO	BREAK PA 70S	825.721	825.721	46
HYDRO	BRIGHT PA 70S	825.721	825.721	48
HYDRO	DOMAL TOP	825.721	825.721	47
HYDRO	STOPPER PG	825.721	825.721	41
IBLEA COLOR	VUERRE 53 TT	825.722	825.722	45
INDINVEST	GOLD 400	825.722	1243.721	46
INDINVEST	GOLD 450	825.722	1243.721	46
INDINVEST	GOLD 450 TT	825.722	1243.721	46
INDINVEST	GOLD 490	825.722	1243.721	46
INDINVEST	GOLD 500	825.722	1243.721	46
INDINVEST	GOLD 502 HC	825.722	1243.721	46
INDINVEST	GOLD 600	825.722	1243.721	46
INDINVEST	GOLD 600 HC-E	825.722	1243.721	46
METRA	NC 50 I	825.721	1243.721	47
METRA	NC 50 STH	825.721	825.721	47
METRA	NC 65 STH	825.721	1243.721	50
METRA	NC 68 STH	825.721	825.721	47
PONZIOSUD	WINDSTOP 45	825.722	1243.721	44
PONZIOSUD	WINDSTOP 45 TT	825.722	1243.721	44
PONZIOSUD	WINDSTOP 55 TT	825.722	1243.721	44
PROFILATI	EKU 52 TT	825.722	825.722	45
PROFILATI	EKU 53	825.722	825.722	45
PROFILATI	EKU 64 TT	825.722	825.722	45
PROFILATI	EKU 66 TT	825.722	825.722	45

(*) Per il corretto posizionamento sul serramento degli incontri ① - ② vedere gli schemi alle pagine 2 - 3 - 5 - 6
 In order to properly position keepers ① - ② on the window/door frame, please refer to the diagrams on pages 2 - 3 - 5 - 6.
 Pour positionner correctement sur l'huissier les gâches ① - ② consultez les schémas des pages 2 - 3 - 5 - 6
 Para el posicionamiento correcto de los topes ① - ② en el cerramiento, véanse los esquemas en las páginas 2 - 3 - 5 - 6
 Zur richtigen Positionierung der Anschläge ① - ② auf dem Verschluss siehe in den Zeichnungen auf den Seiten 2 - 3 - 5 - 6
 Dla prawidłowego pozycjonowania na oknie podkładek ① - ② zobacz schematy na stronach 2 - 3 - 5 - 6
 Для правильного расположения на окне ответных планок ① - ② см. схемы на стр. 2 - 3 - 5 - 6

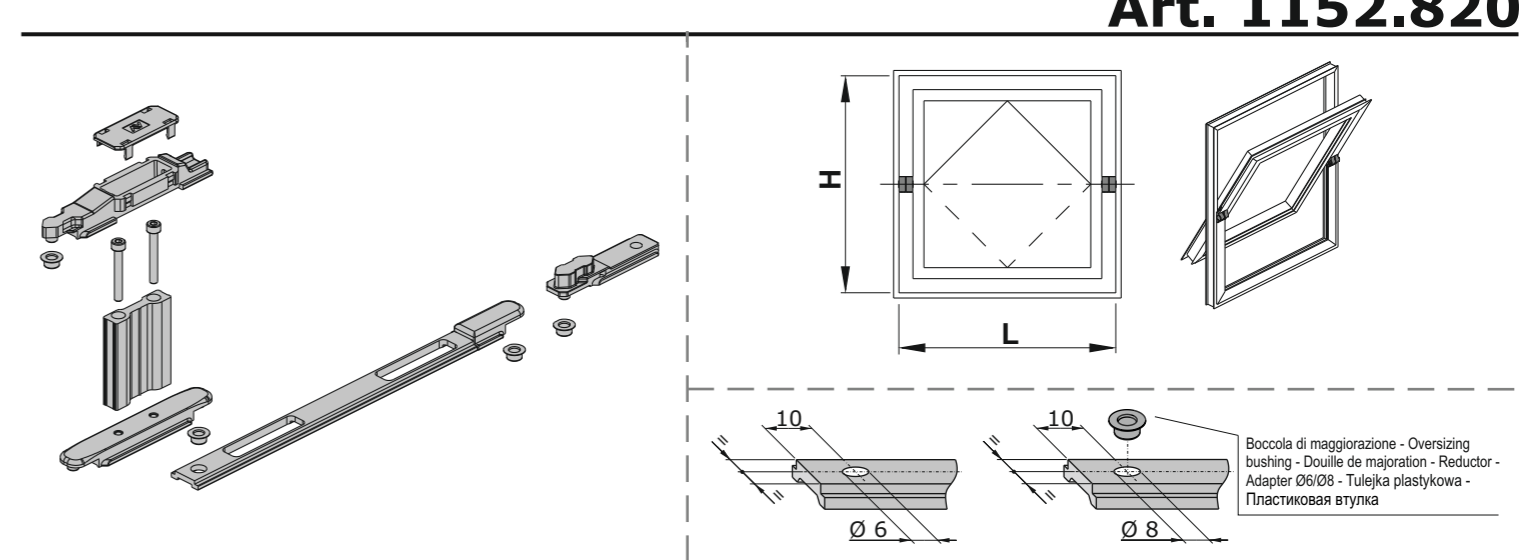

ANTA - LEAF - VANTAIL - HOJA - FLÜGEL - SKRZYDŁO - СТВОРКА

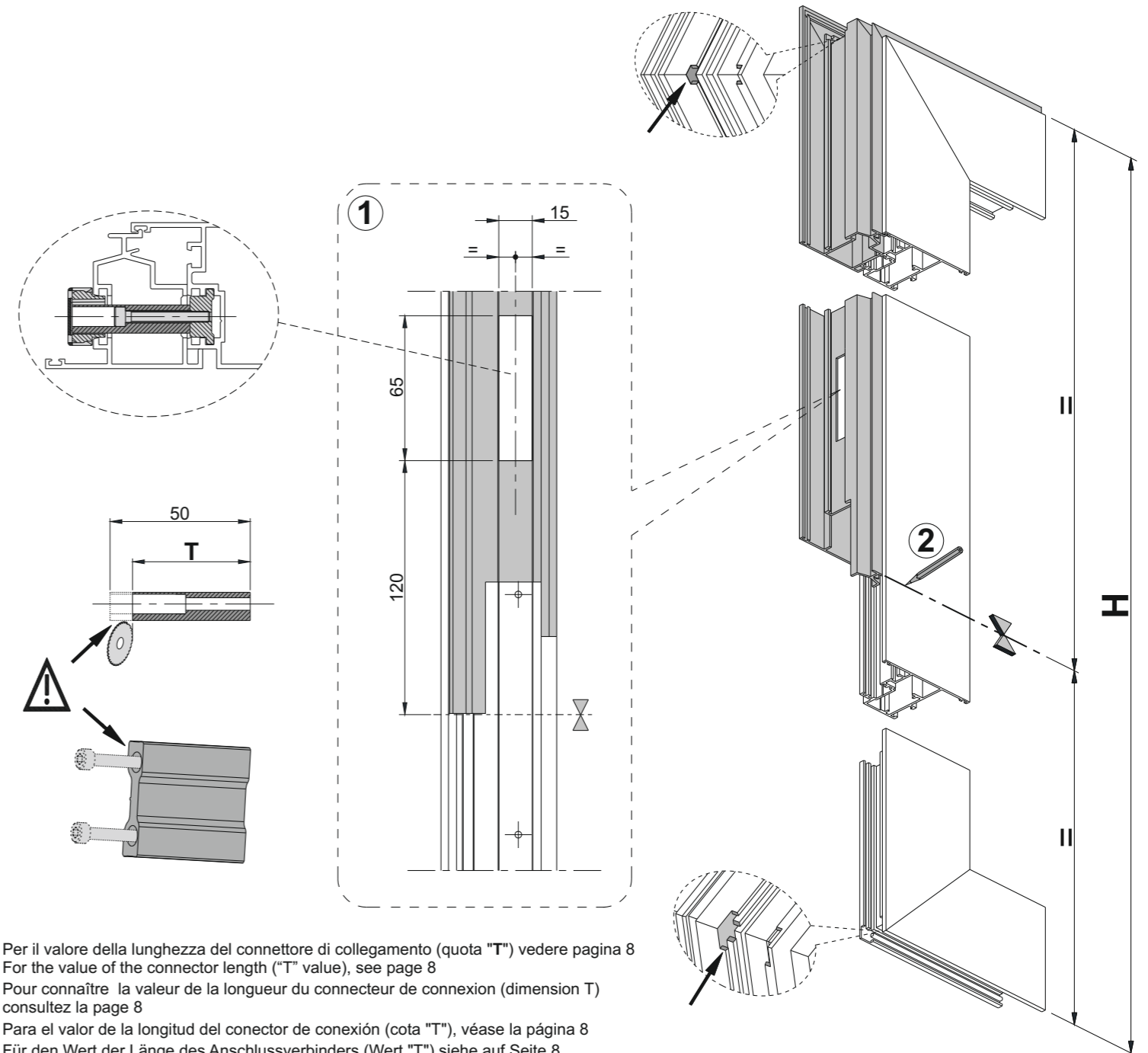

Per il valore della lunghezza del connettore di collegamento (quota "T") vedere pagina 8
 For the value of the connector length ("T" value), see page 8
 Pour connaître la valeur de la longueur du connecteur de connexion (dimension T) consultez la page 8
 Para el valor de la longitud del conector de conexión (cota "T"), véase la página 8
 Für den Wert der Länge des Anschlussverbinders (Wert "T") siehe auf Seite 8
 Długość łącznika (wymiar "T"), podana jest na stronie 8
 Для определения длины соединительного элемента (значение "T") см. стр. 8

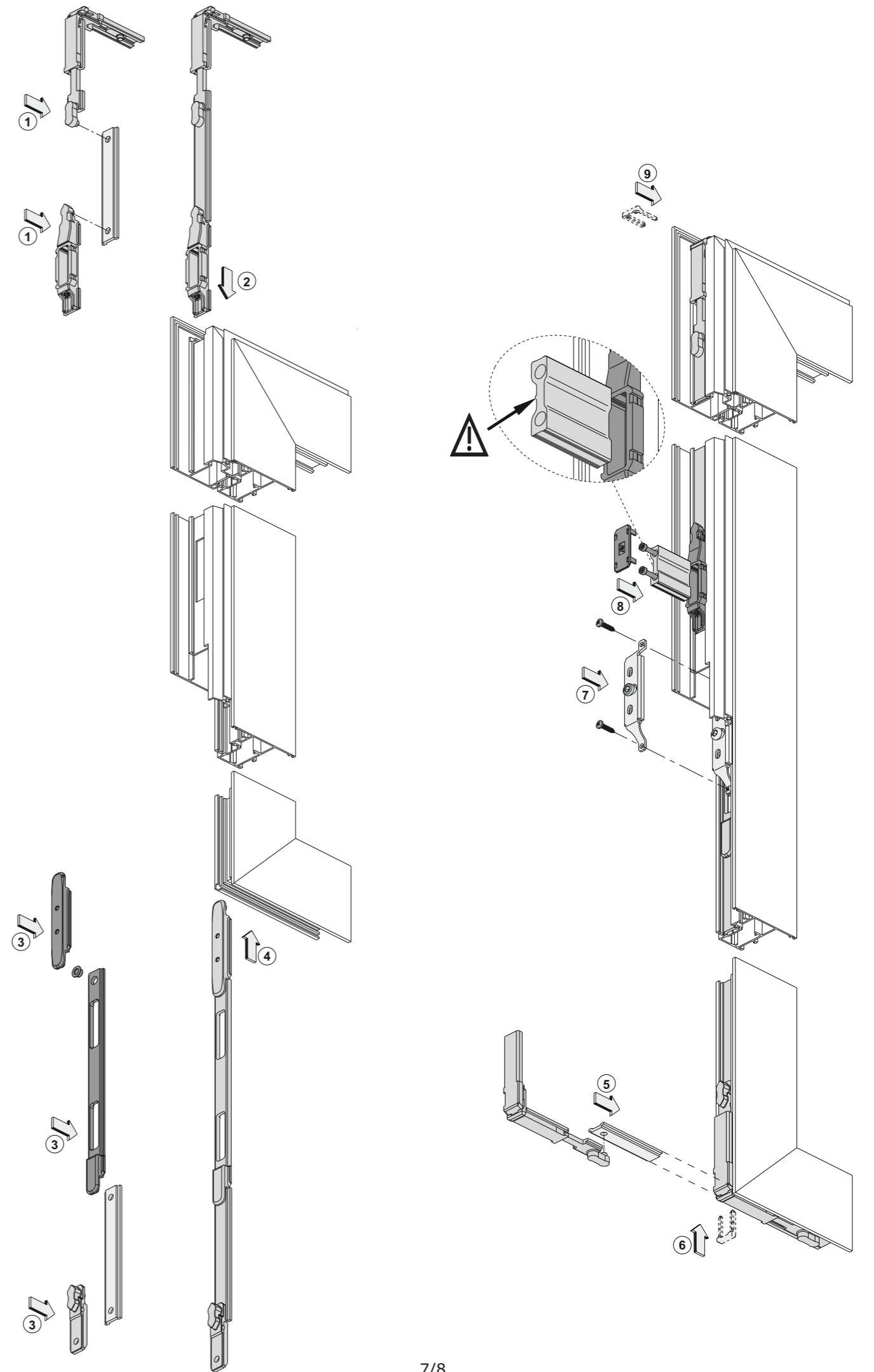
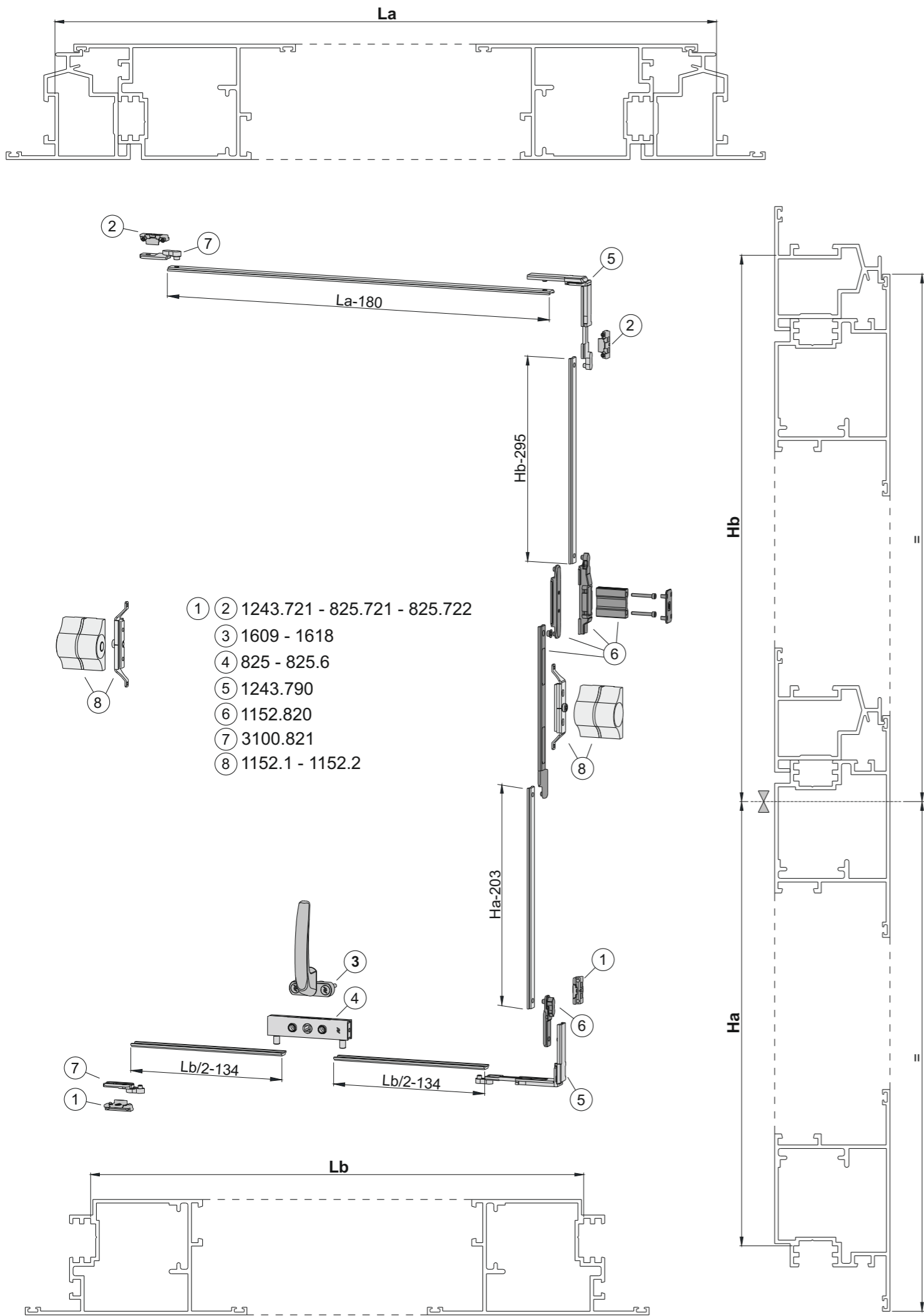

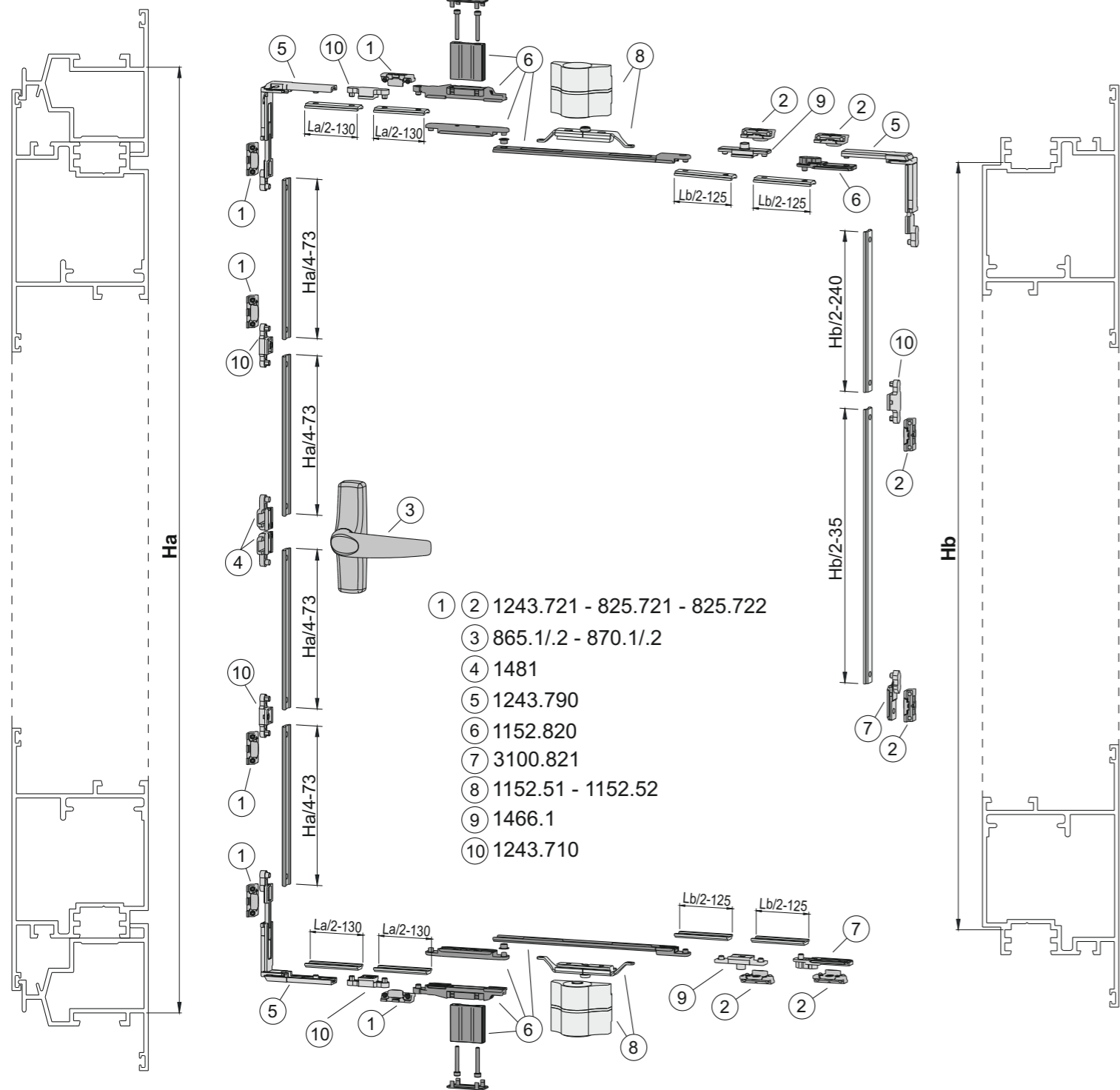
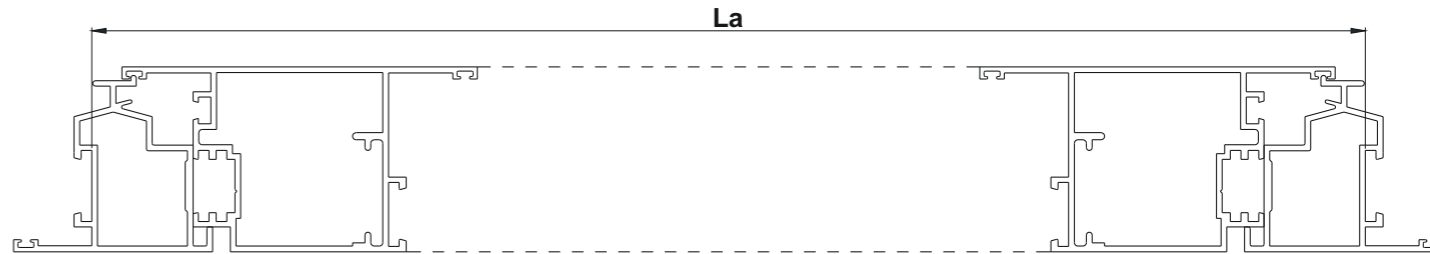
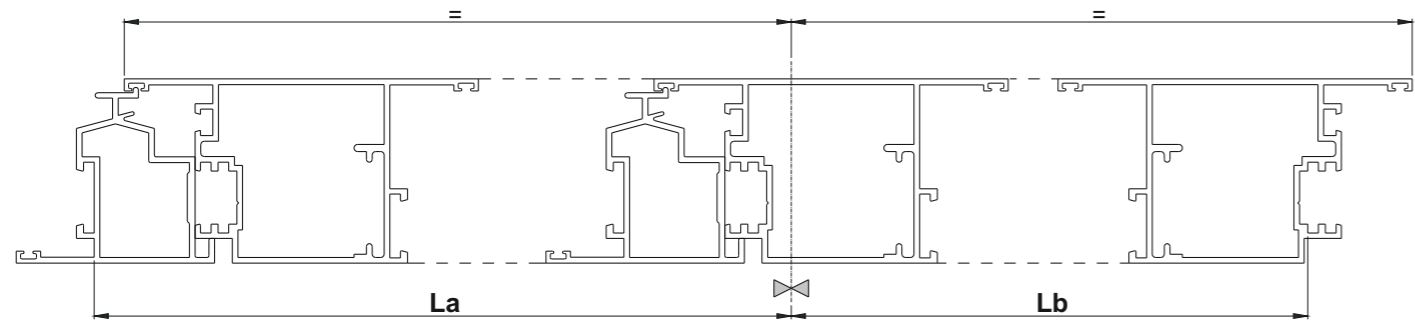

- ① ② 1243.721 - 825.721 - 825.722
- ③ 865.1/.2 - 870.1/.2
- ④ 1481
- ⑤ 1243.790
- ⑥ 1152.820
- ⑦ 3100.821
- ⑧ 1152.51 - 1152.52
- ⑨ 1466.1
- ⑩ 1243.710

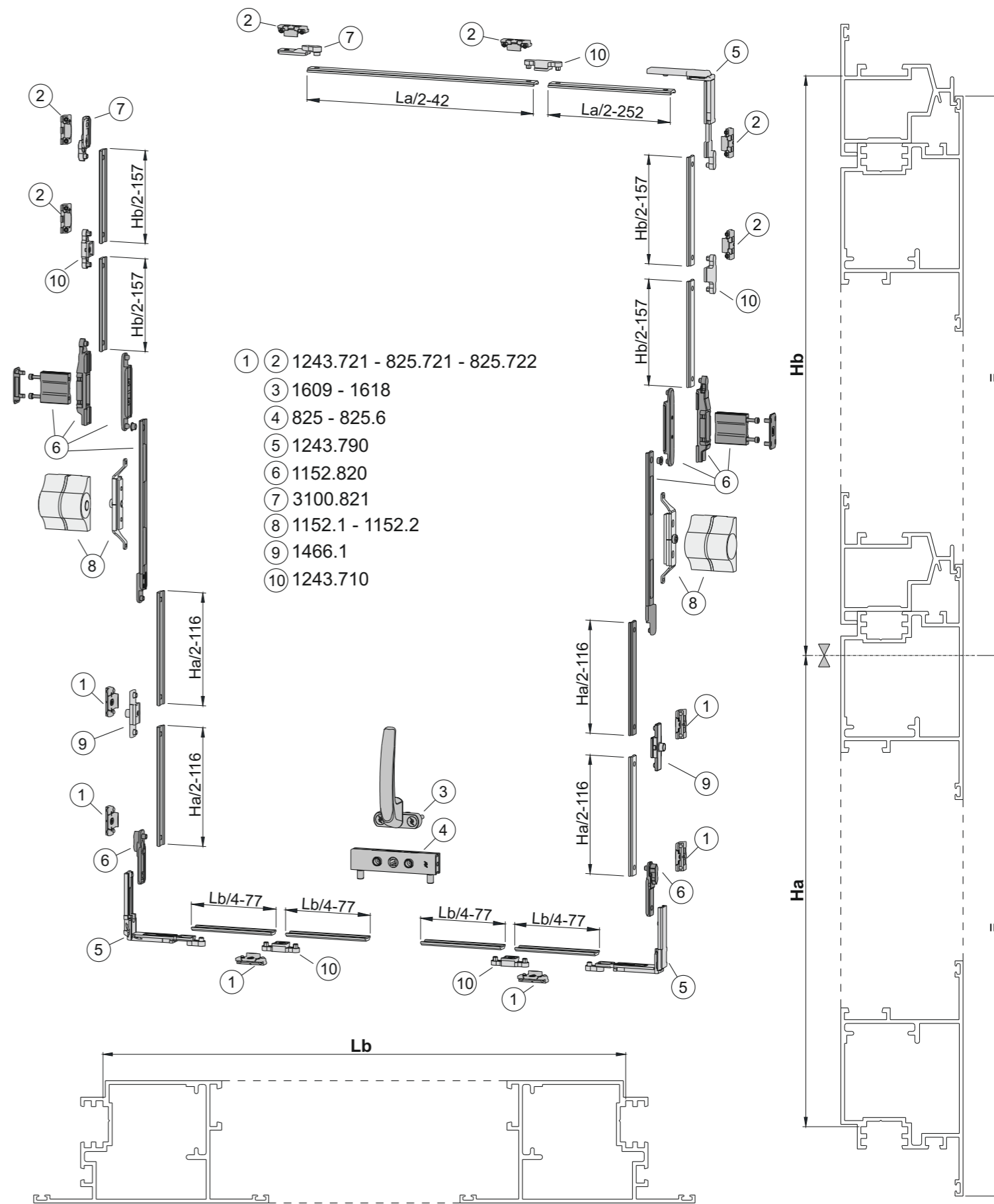

- ① ② 1243.721 - 825.721 - 825.722
- ③ 1609 - 1618
- ④ 825 - 825.6
- ⑤ 1243.790
- ⑥ 1152.820
- ⑦ 3100.821
- ⑧ 1152.1 - 1152.2
- ⑨ 1466.1
- ⑩ 1243.710

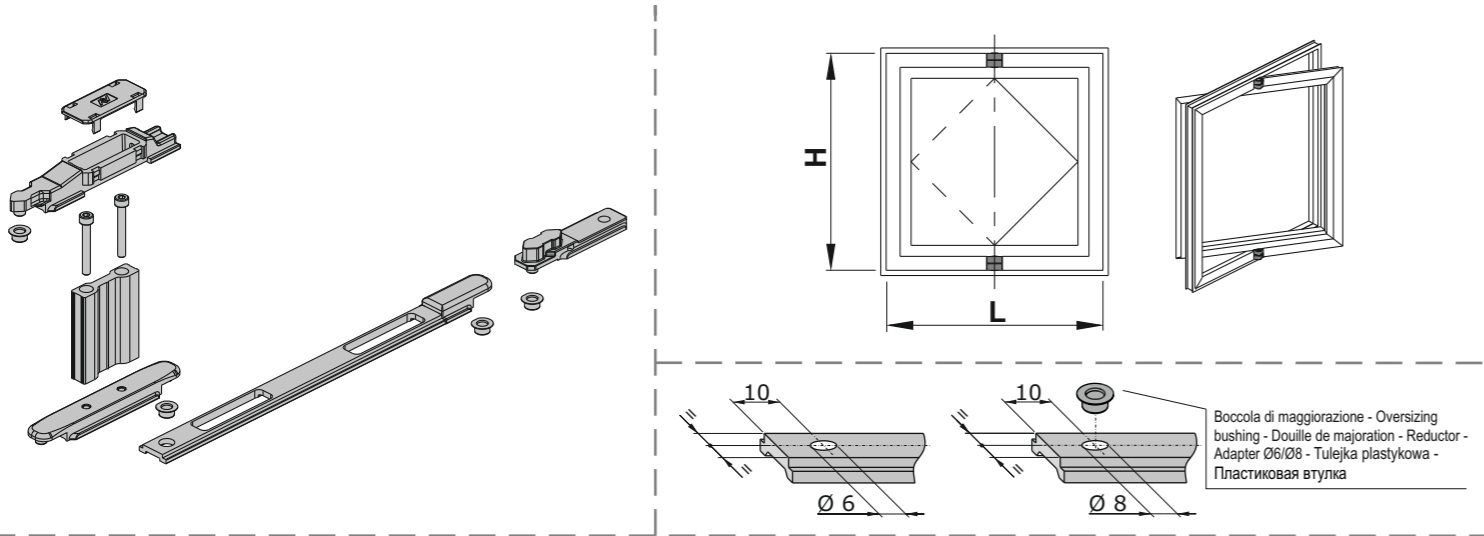

ANTA - LEAF - VANTAIL - HOJA - FLÜGEL - SKRZYDŁO - СТВОРКА

Per il valore della lunghezza del connettore di collegamento (quota "T") vedere pagina 8 - For the value of the connector length ("T" value), see page 8
 Pour connaître la valeur de la longueur du connecteur de connexion (dimension T) consultez la page 8 - Para el valor de la longitud del conector de conexión (cota "T"), véase la página 8 - Für den Wert der Länge des Anschlussverbinders (Wert "T") siehe auf Seite 8 - Długość łącznika (wymiar "T"), podana jest na stronie 8
 Для определения длины соединительного элемента (значение "Т") см. стр. 8

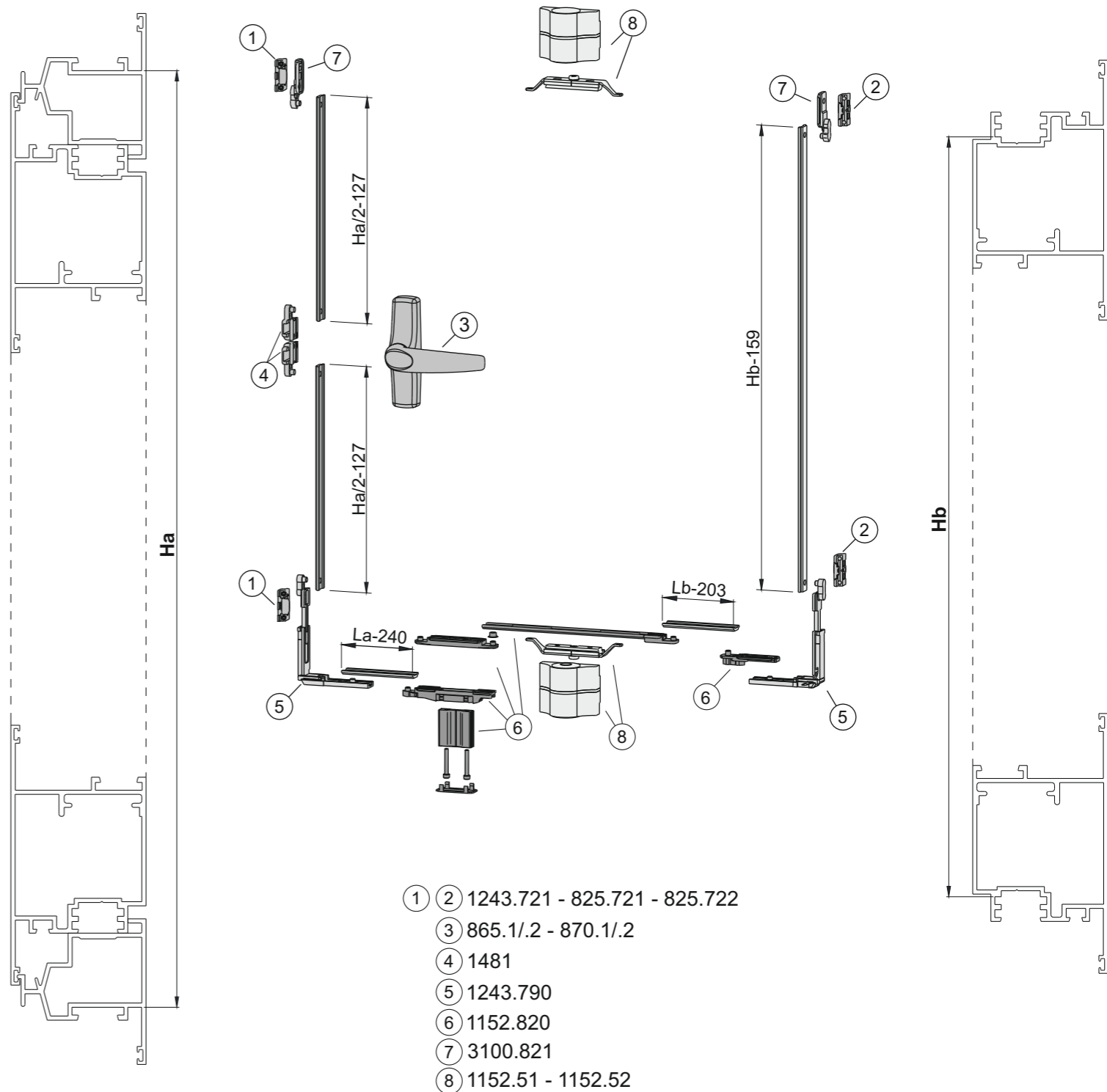
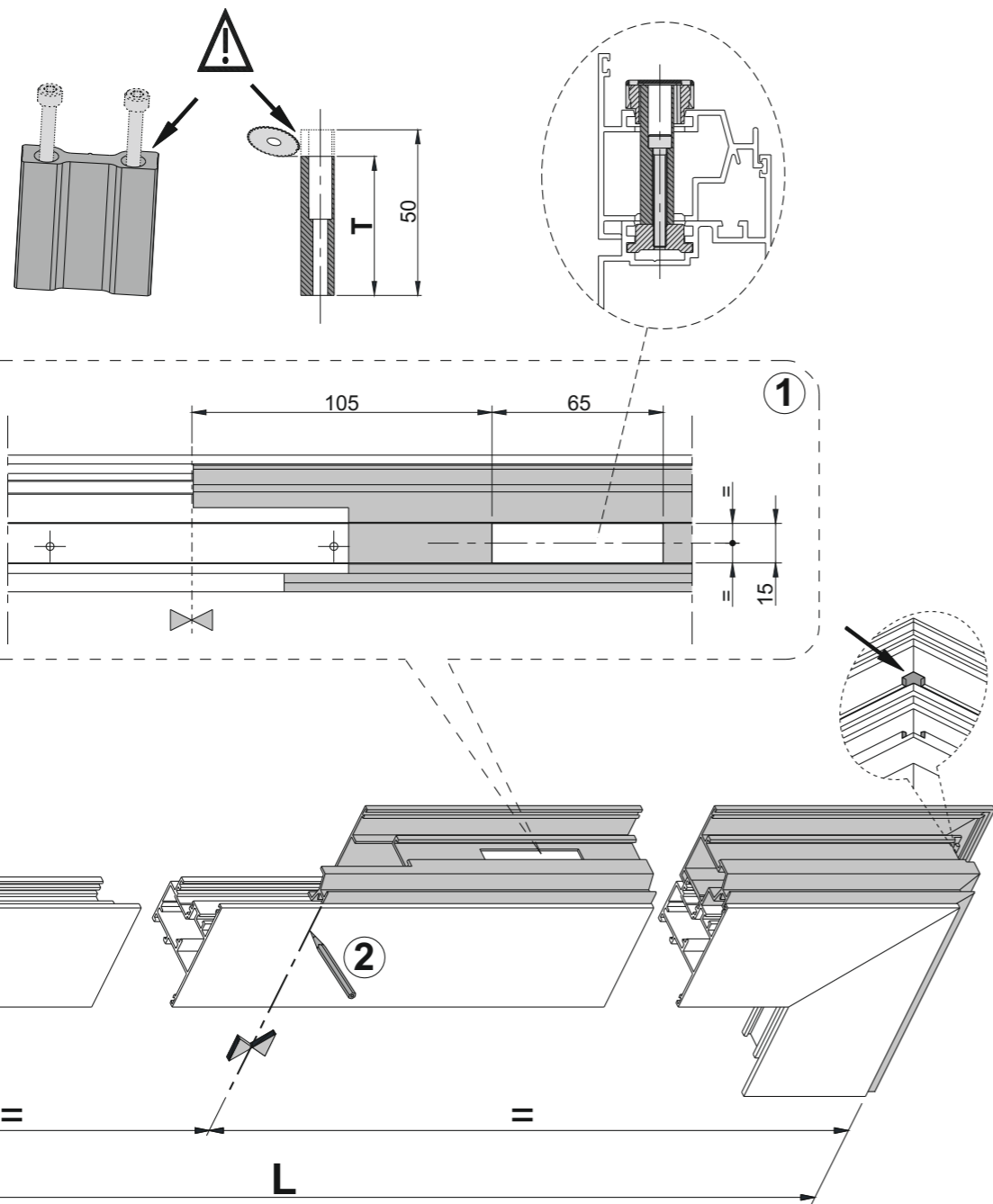

- ① ② 1243.721 - 825.721 - 825.722
- ③ 865.1/.2 - 870.1/.2
- ④ 1481
- ⑤ 1243.790
- ⑥ 1152.820
- ⑦ 3100.821
- ⑧ 1152.51 - 1152.52

