

Art. 1481.4/16 -1481.4/19

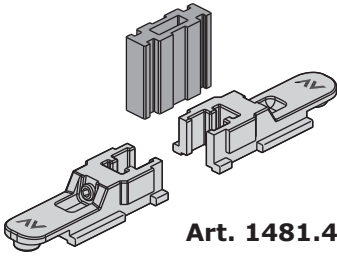

Art. 1481.4/16

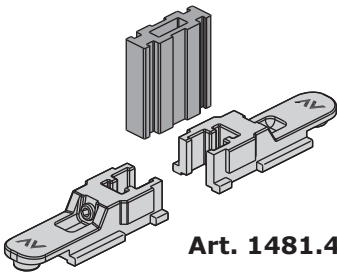

Art. 1481.4/19

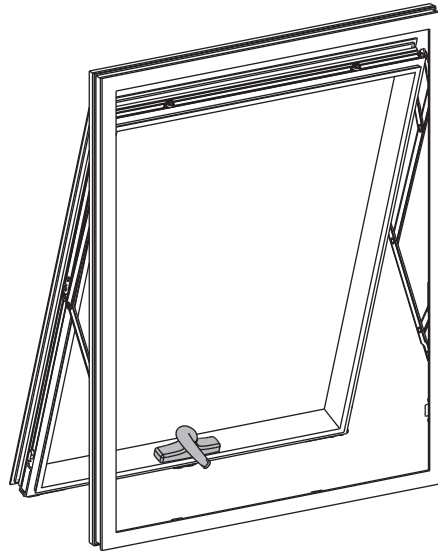

Lavorazione su anta - Leaf machining - Usinage sur le vantail - Mecanizado sobre la hoja - Flügel Vorarbeitung

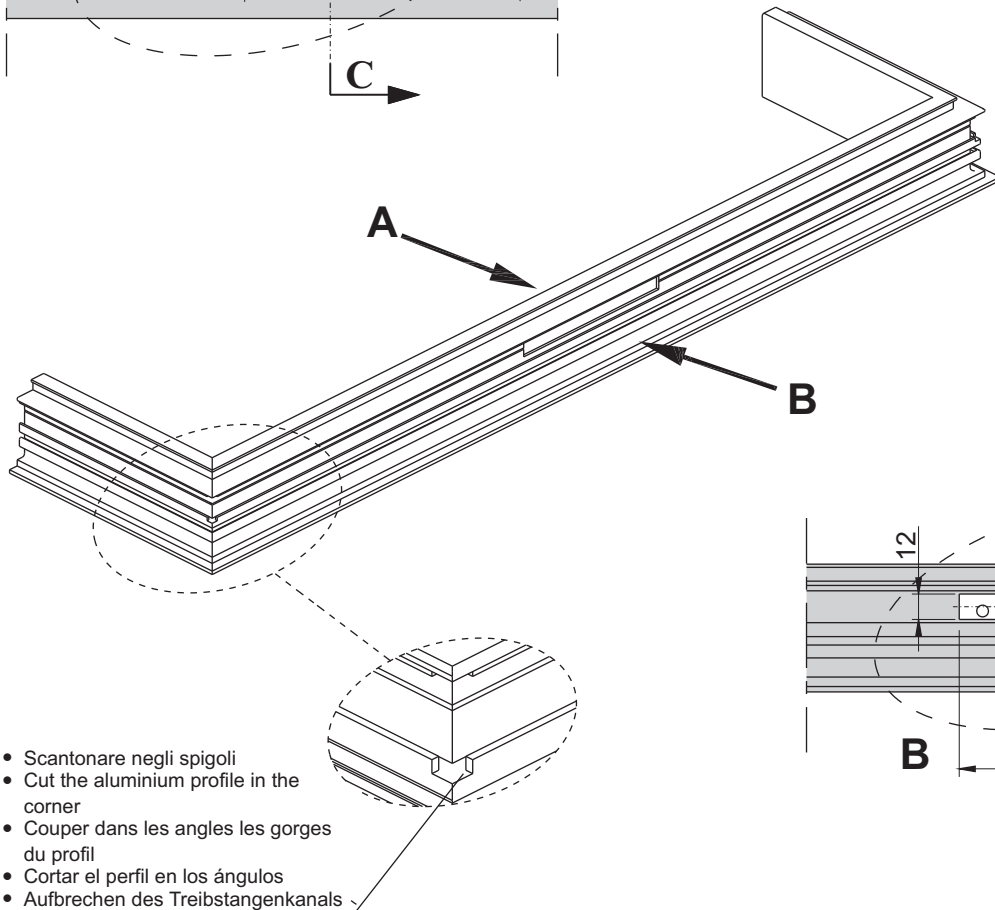
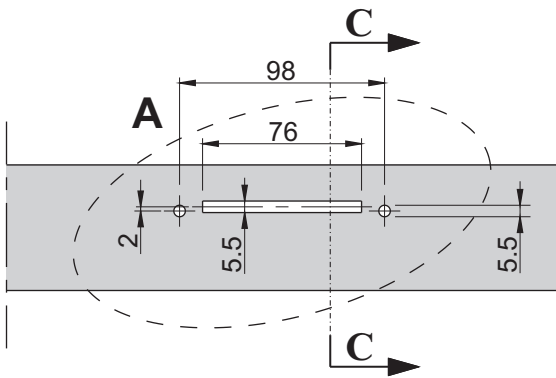

SEZ. C-C

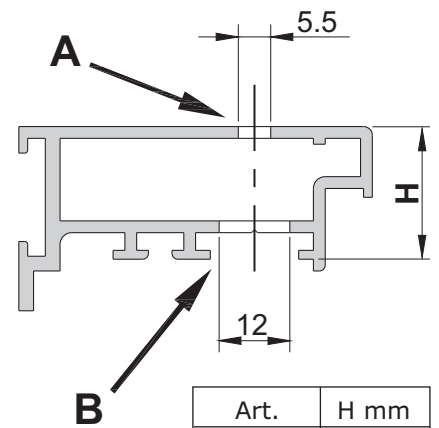

Art.	H mm
1481.4/16	16.5÷23
1481.4/19	23÷29.5

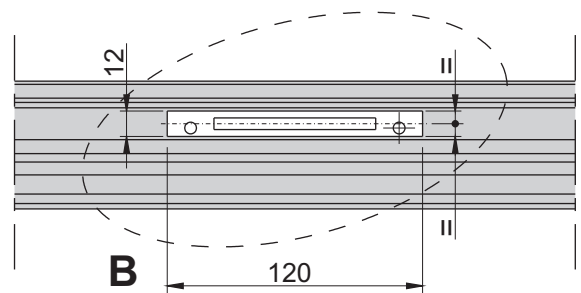

- Scantonare negli spigoli
- Cut the aluminium profile in the corner
- Couper dans les angles les gorges du profil
- Cortar el perfil en los ángulos
- Aufbrechen des Treibstangenkanals

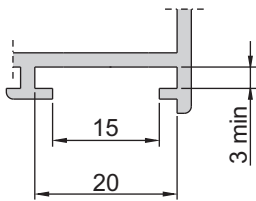

Lavorazione su asta
rod machining
Usinage sur la tringle
Mecanizado sobre la pletina
Getriebstab Vorarbeitung

