

# Art. 1481.704/16 -1481.704/19

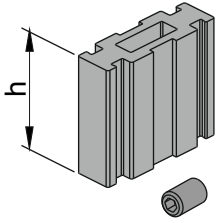

Art.	h mm
1481.704/16	25
1481.704/19	31

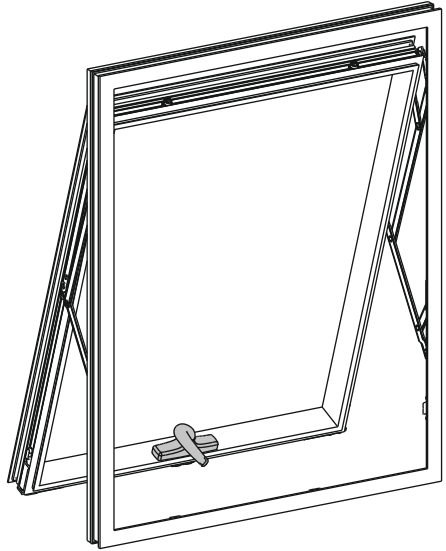
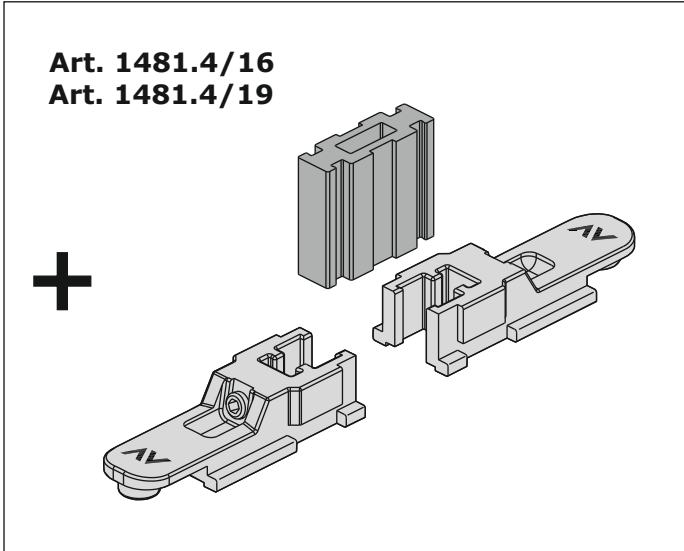

Lavorazione su anta - Leaf machining - Usinage sur le vantail - Mecanizado sobre la hoja - Flügel Vorarbeitung

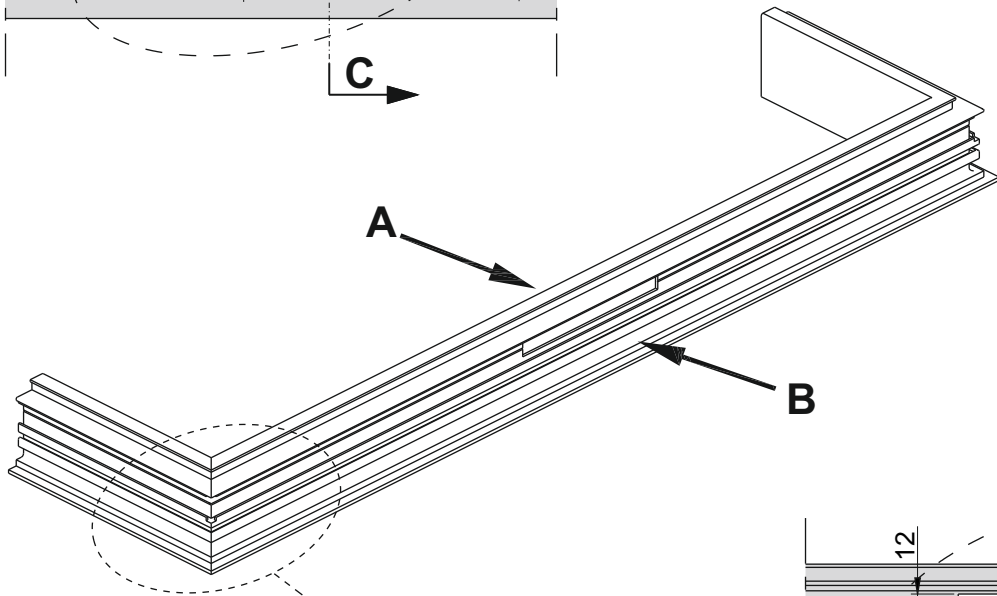
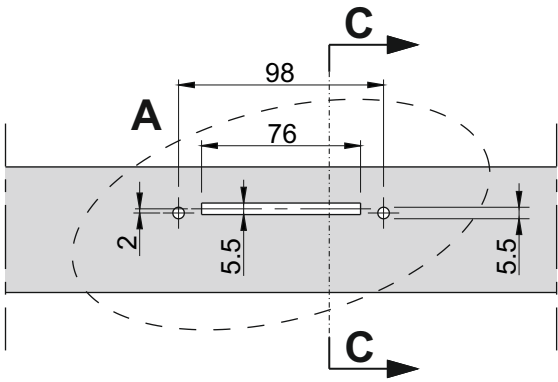

## SEZ. C-C

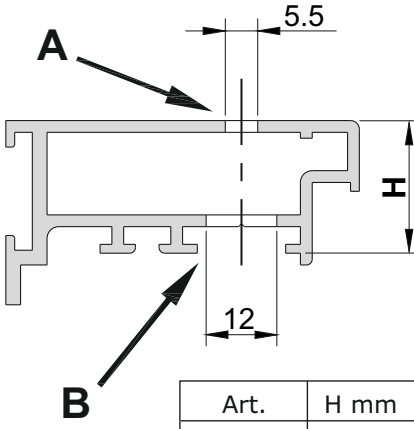

Art.	H mm
1481.4/16	16.5÷23
1481.4/19	23÷29.5

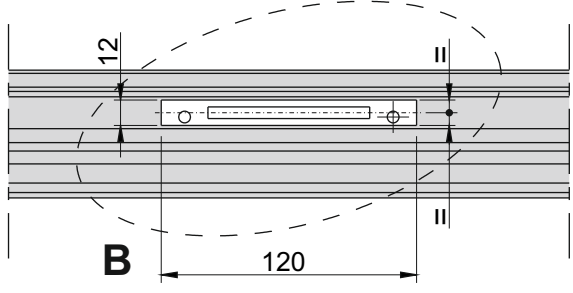

- Scantonare negli spigoli
- Cut the aluminium profile in the corner
- Couper dans les angles les gorges du profil
- Cortar el perfil en los ángulos
- Aufbrechen des Treibstangenkanals

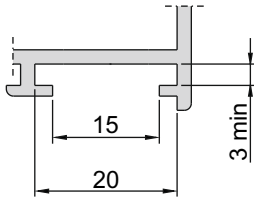

Lavorazione su asta  
rod machining  
Usinage sur la tringle  
Mecanizado sobre la pletina  
Getriebstab Vorarbeitung

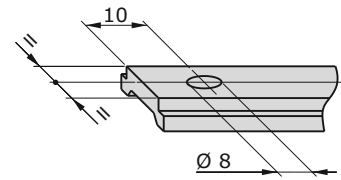

Art. 875.82 R/L - 875.754 R

