

E' possibile ridurre la quota L tagliando il quadro da 8 mm
It's possible to reduce quote L cutting the 8 mm square pin

Per il fissaggio è possibile utilizzare dei rivetti M4 o dadi M5 con viti a testa piana svasata di lunghezza L + 27 mm.

For the fixing it is possible to use rivets M4 or hexagonal nuts M5 with countersunk head screws (L+27 mm length)

Lavorazioni - Machinings

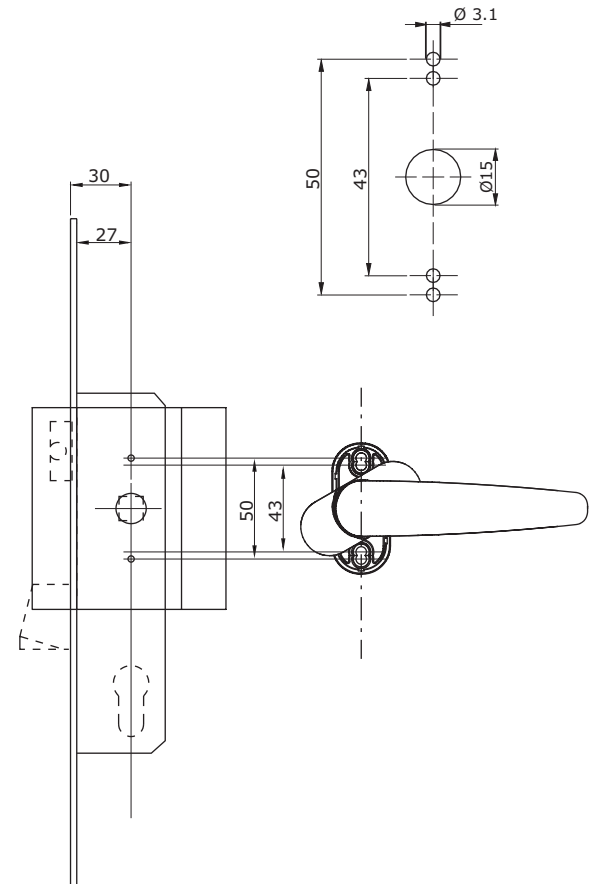
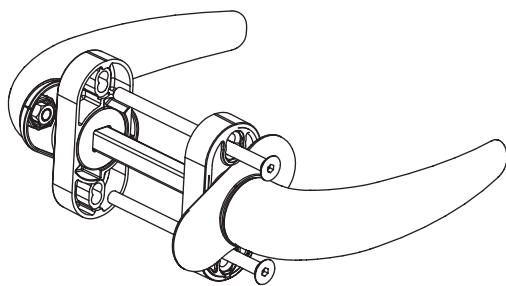

Dado M5
hexagonal nuts M5

Rivetti M4
Rivets M4

