

POSIZIONAMENTO ACCESSORI SU TELAIO FISSO (DESTRO)
 ACCESSORIES POSITIONING ON FIXED FRAME (RH)
 MONTAGE DES ACCESSOIRES SUR LE DORMANT (DROIT)
 EMPLAZAMIENTO DE LOS ACCESORIOS SOBRE EL MARCO FIJO (DERECHO)
 POSITIONIERUNG D.BESCHLÄGE AM FENSTERRAHMEN (RECHTS)

L < 1400 mm - H < 1700 mm

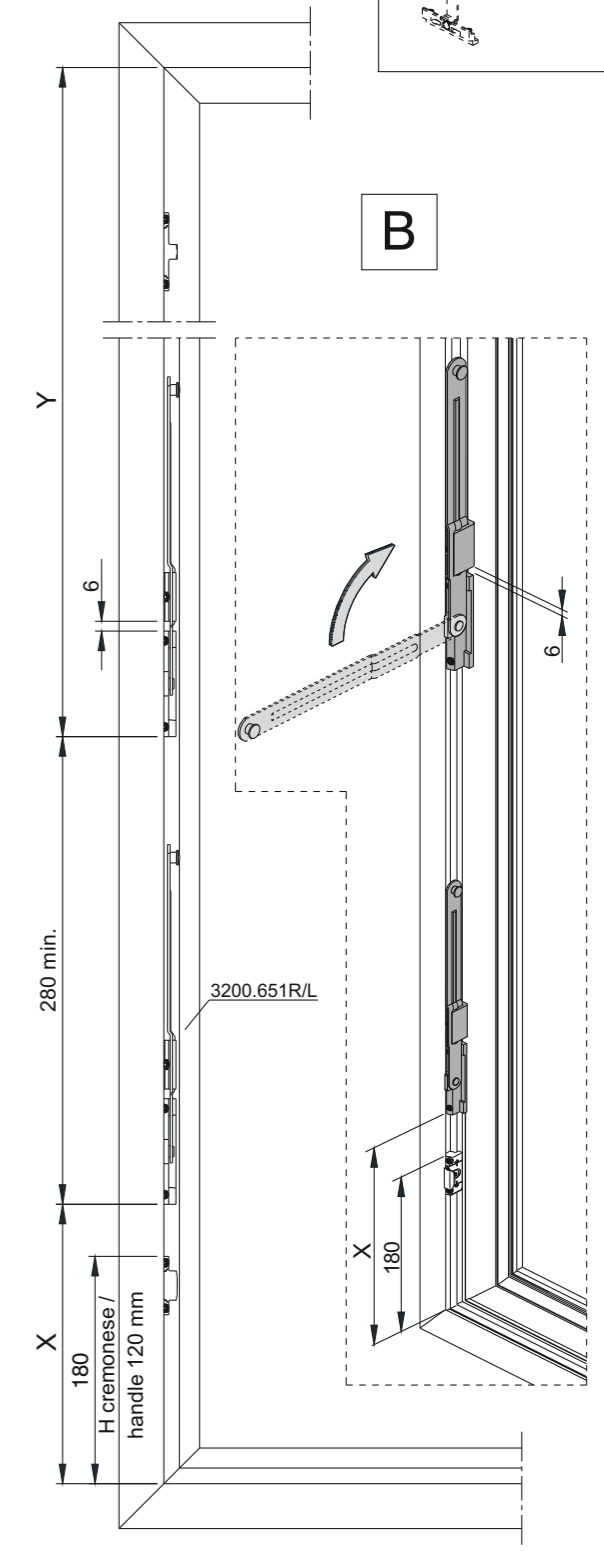
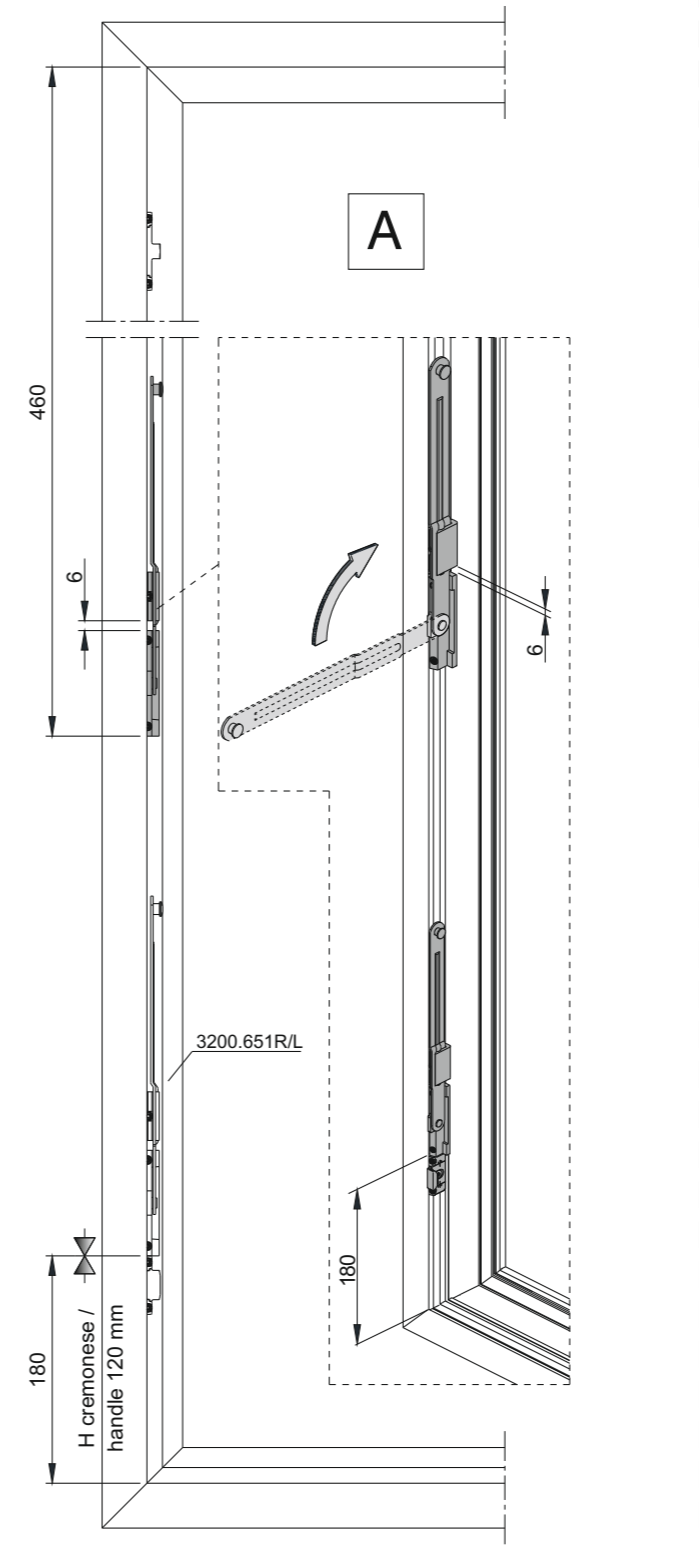
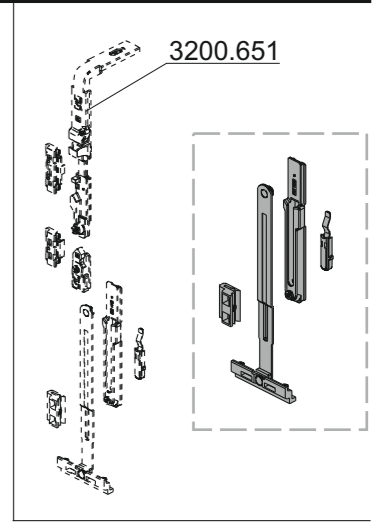
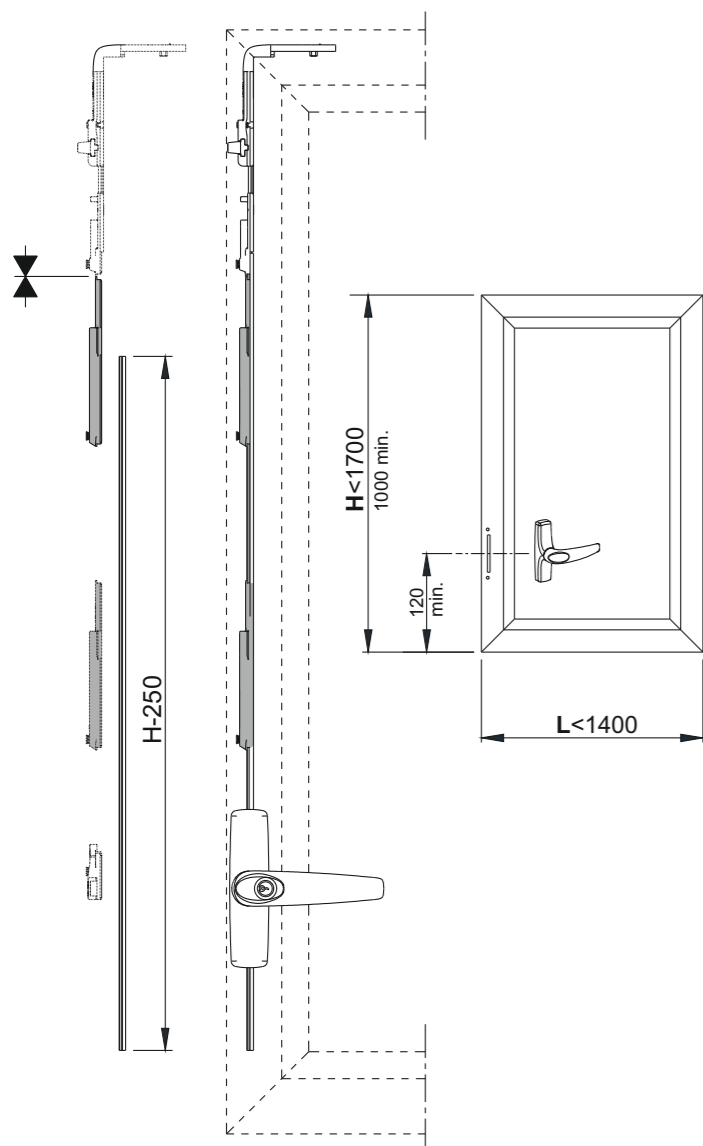
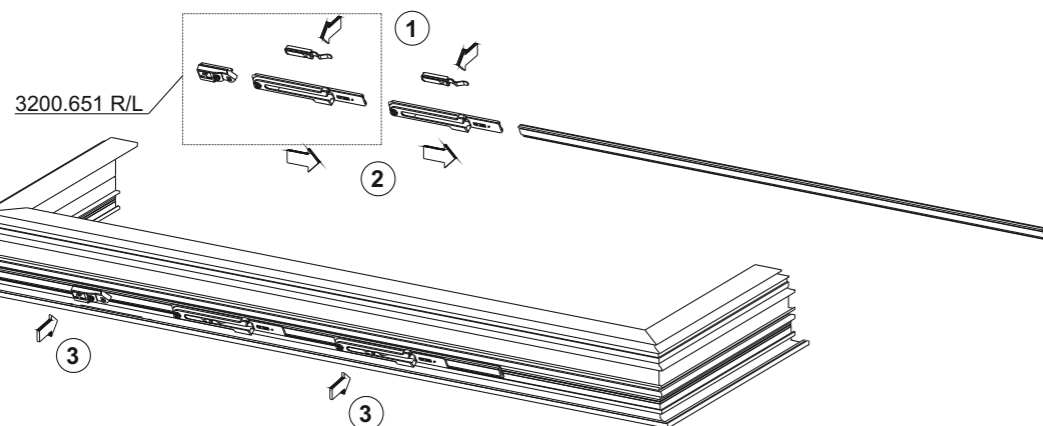
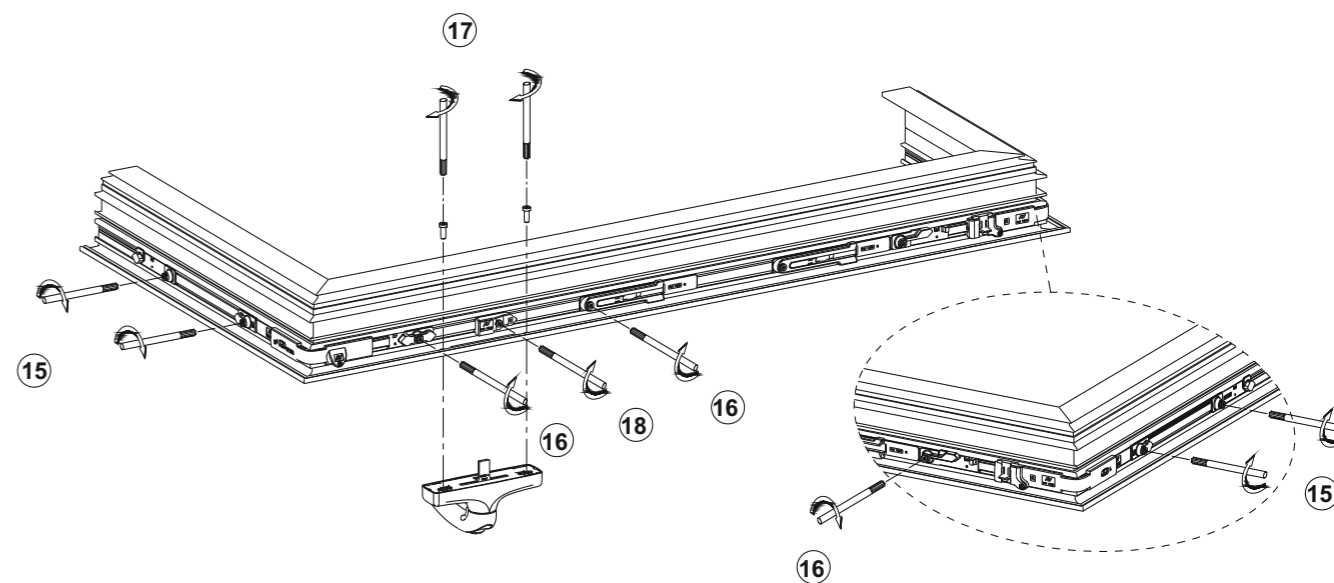
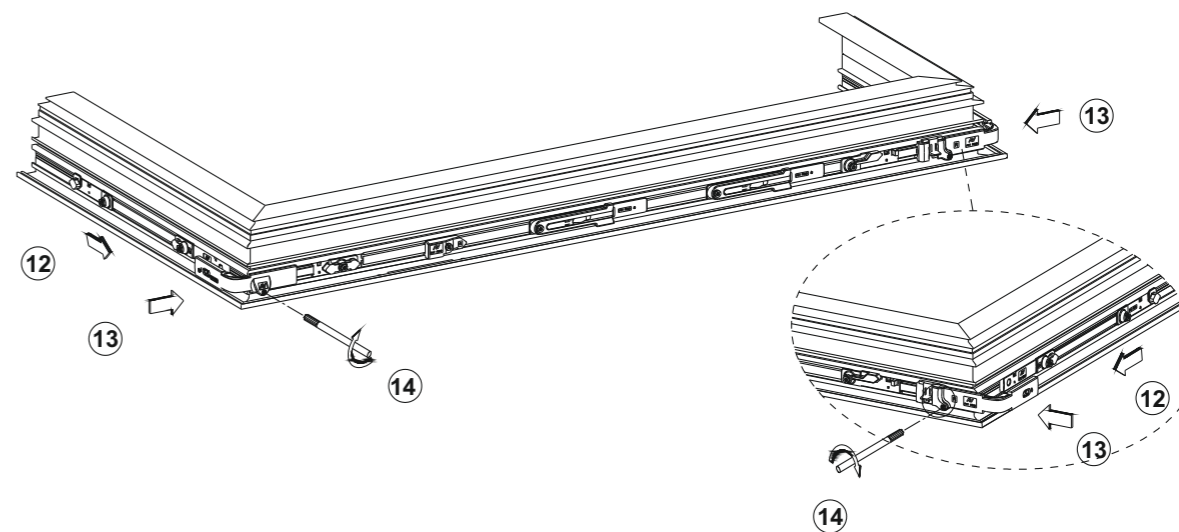
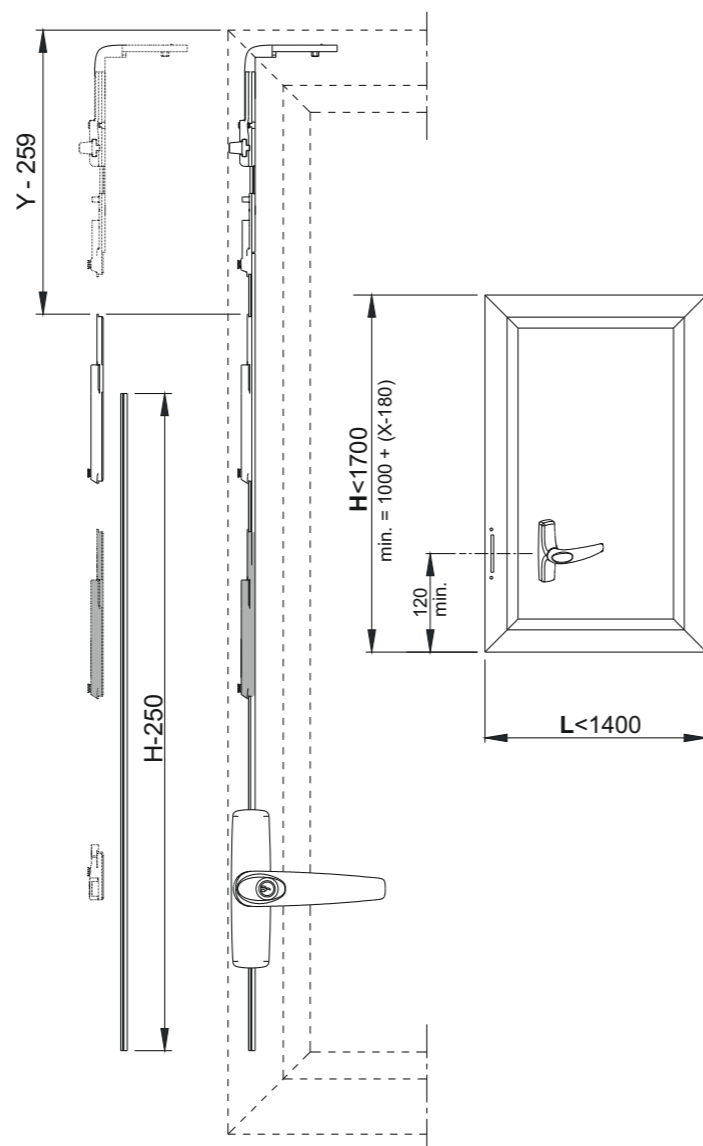

A**B**

Prima di inserire l'anta nel telaio, ruotare l'impugnatura cremonese come indicato in fig.1 premendo contemporaneamente la linguetta R della falsa manovra.

Before inserting the sash on the frame, turn the grip handle as shown on picture 1, pressing at the same time, R part of mishandling element.

Avant d'introduire le vantail dans le dormant, tourner la crémonne comme indiqué par le dessin 1, et en même temps presser la pièce R du dispositif de la fausse manoeuvre.

Antes la introducción de la hoja dentro del marco, emplazar la cremona como indicado por el dibujo 1, haciendo presión al mismo tiempo sobre la pieza R de la falsa maniobra.

Vor dem Einbau des Flügels in den Blendrahmen den Getriebegriff laut Abb. 1 drehen und gleichzeitig auf die Feder R der Fehlbedienung drücken.

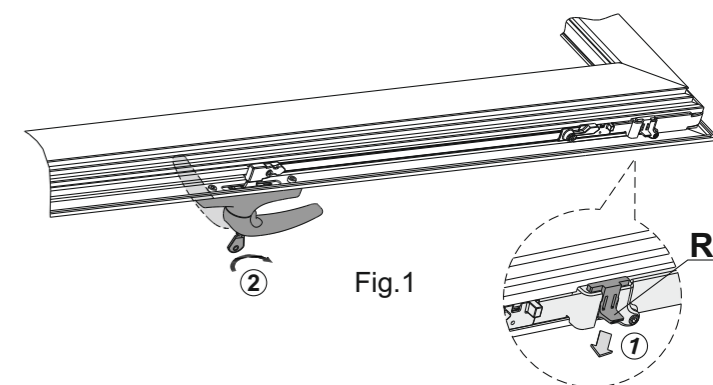

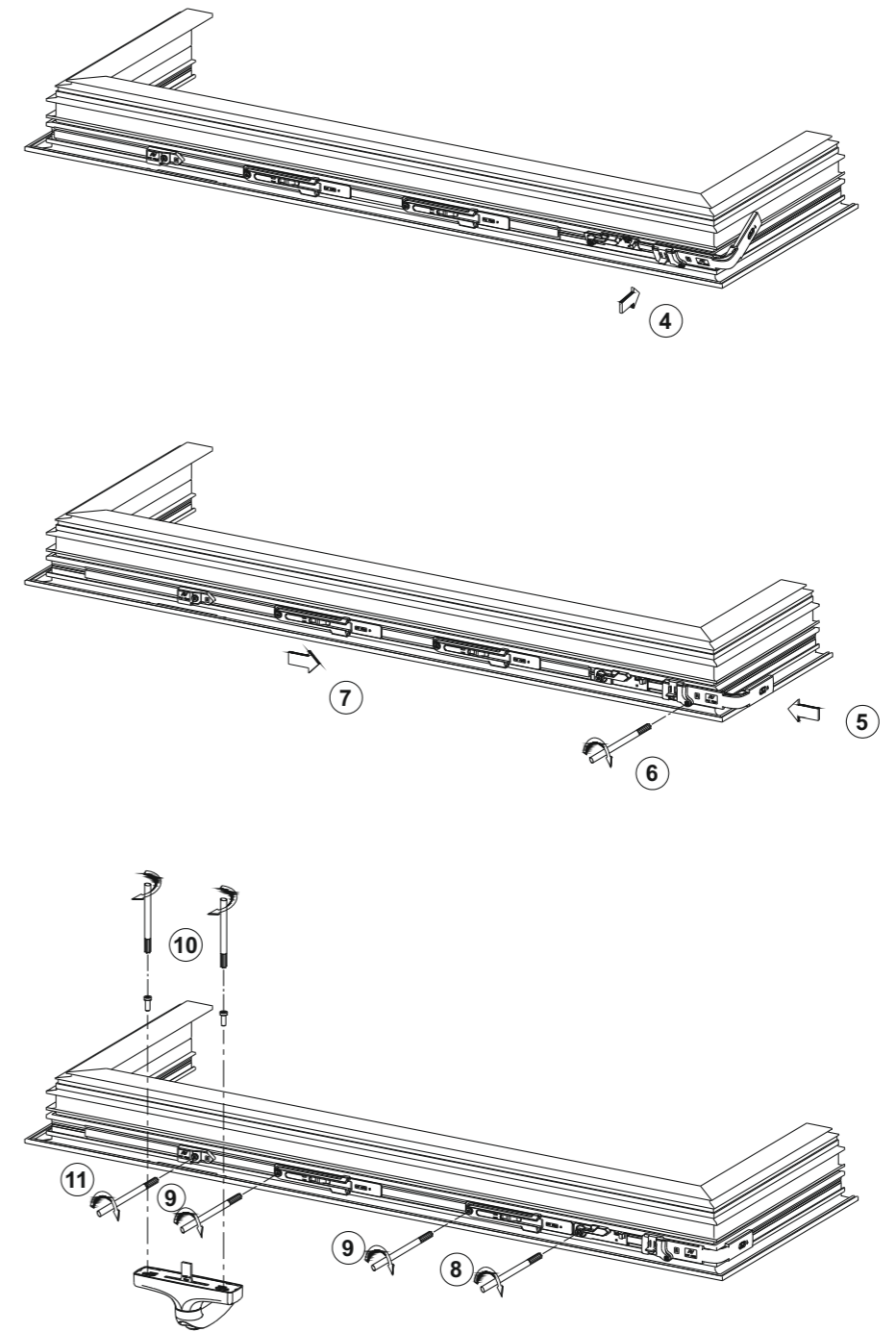
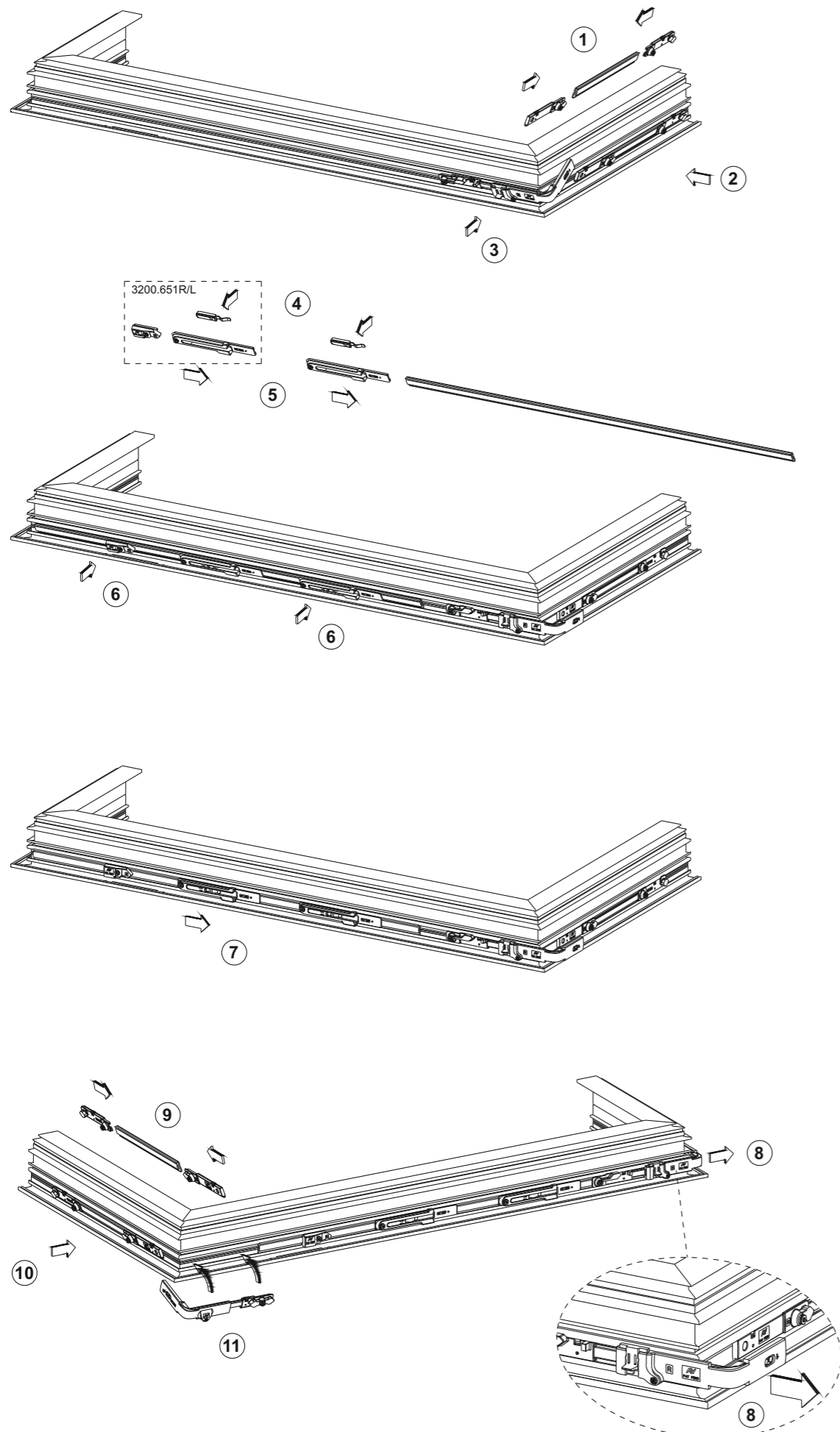

Prima di inserire l'anta nel telaio, ruotare l'impugnatura cremonese come indicato in fig.1 premendo contemporaneamente la linguetta R della falsa manovra.

Before inserting the sash on the frame, turn the grip handle as shown on picture 1, pressing at the same time, R part of mishandling element.

Avant d'introduire le vantail dans le dormant, tourner la crémonne comme indiqué par le dessin 1, et en même temps presser la pièce R du dispositif de la fausse manoeuvre.

Antes la introducción de la hoja dentro del marco, emplazar la cremone como indicado por el dibujo 1, haciendo presión al mismo tiempo sobre la pieza R de la falsa maniobra.

Vor dem Einbau des Flügels in den Blendrahmen den Getriebegriff laut Abb. 1 drehen und gleichzeitig auf die Feder R der Fehlbedienung drücken.

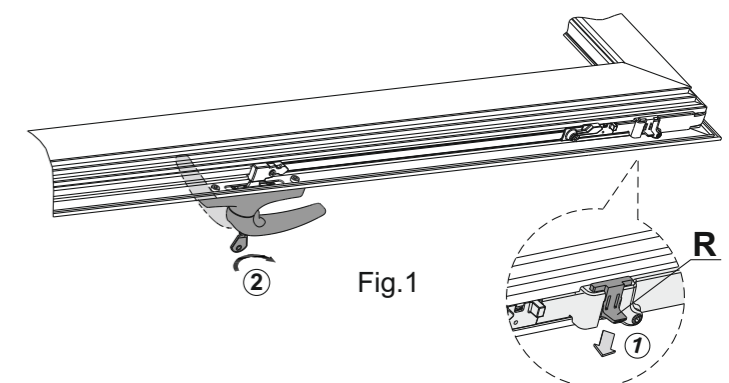

L<1500 mm - H<1700 mm

C

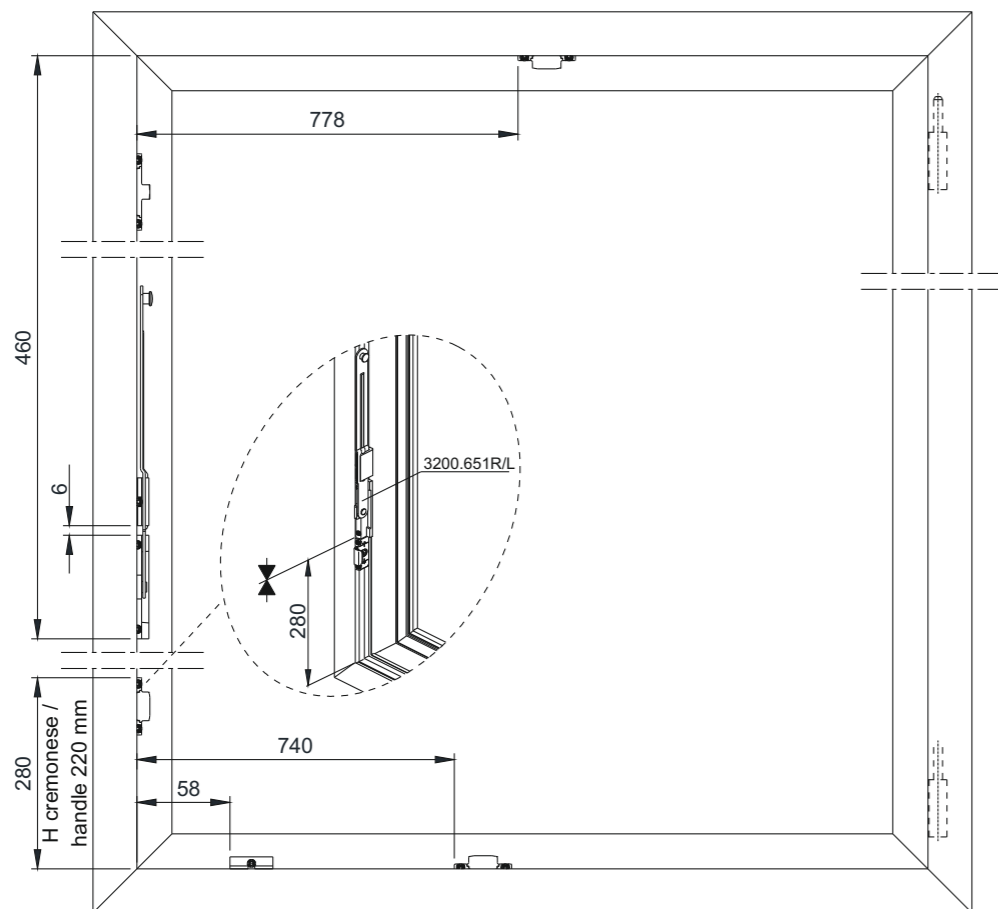

C

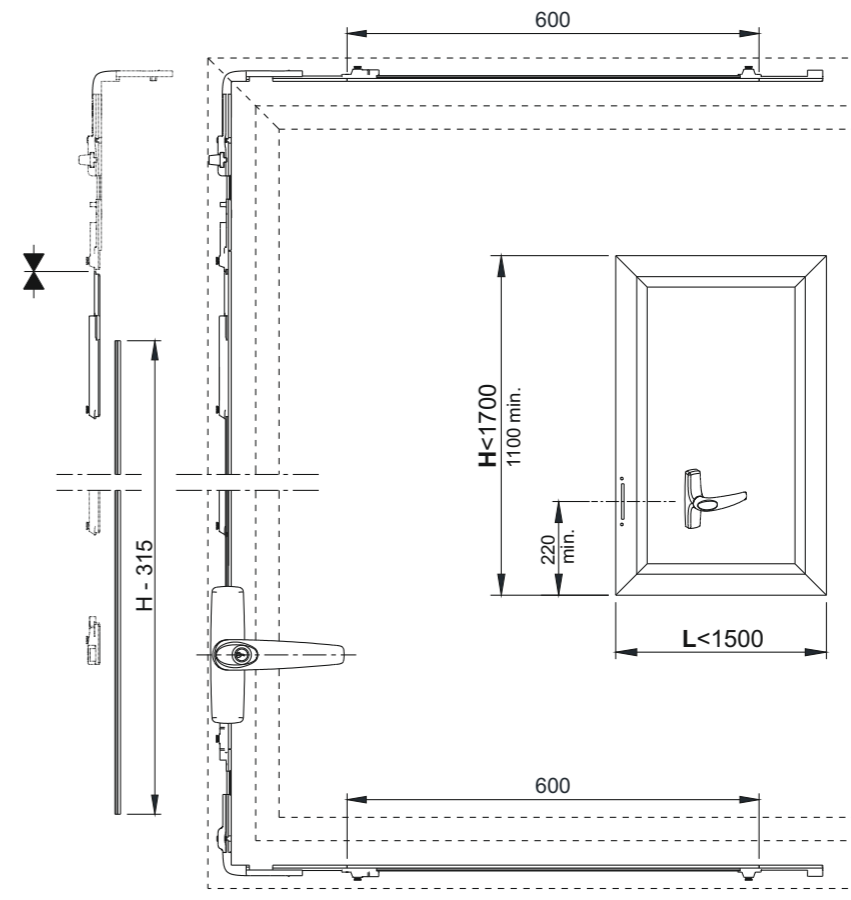

D

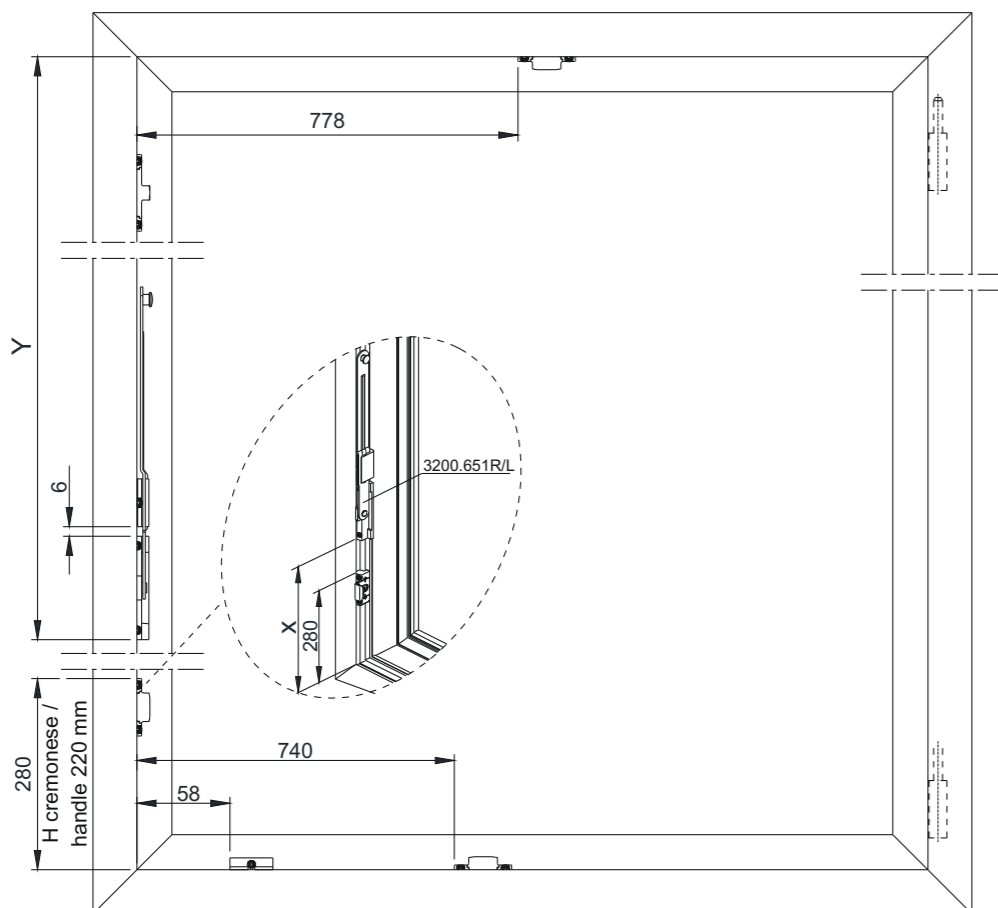

D

