

W_{min}. 450 W_{min}. 17.72

H_{min}. 506.68 H_{min}. 19.95

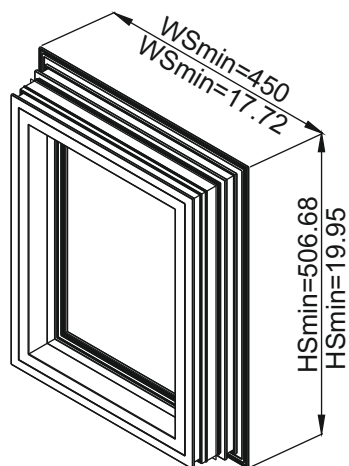

Art.:1208.1R

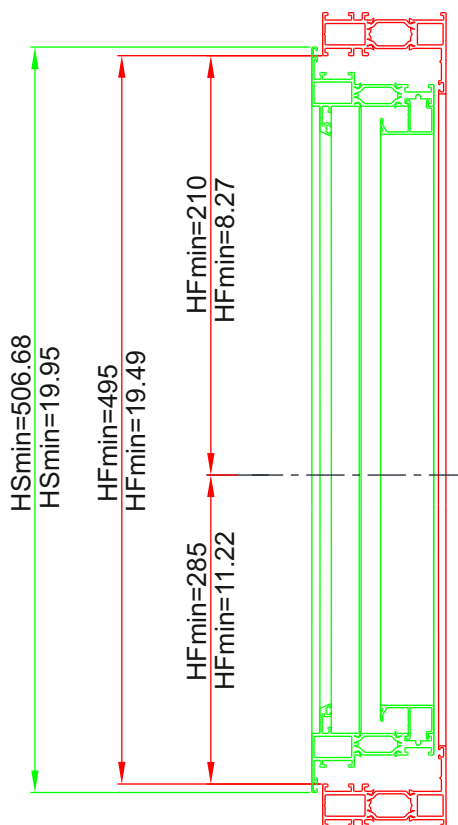
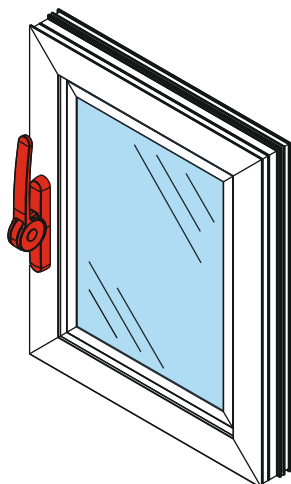
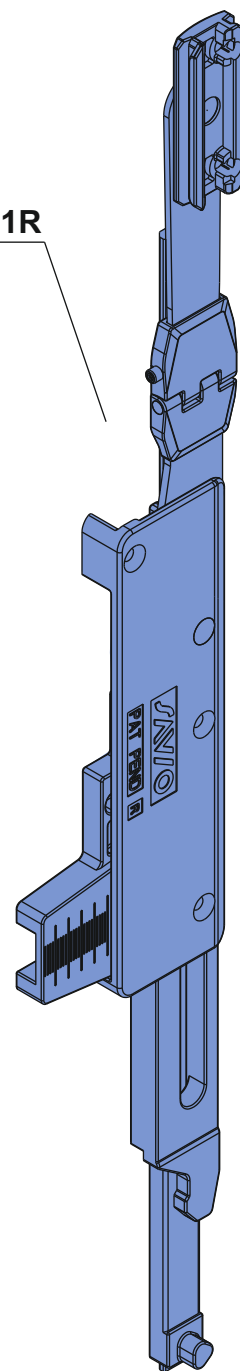

Art.:1208

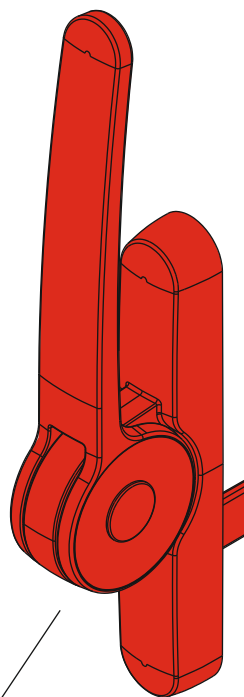

Art.:1208.701

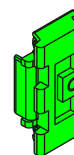

LAVORAZIONE TELAIO FRAME MACHINING

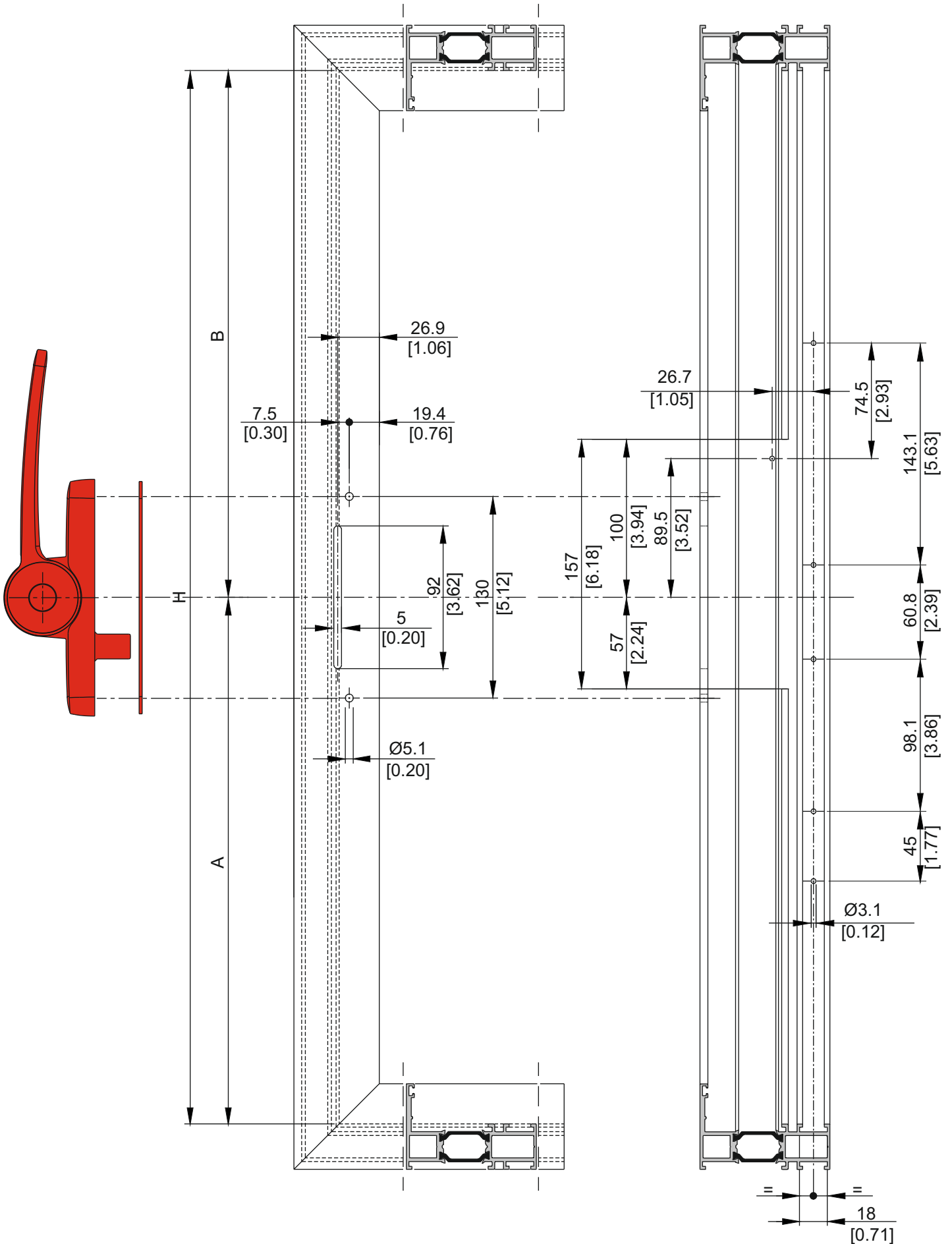

LAVORAZIONE ANTA MOBILE MOVING LEAF MACHINING

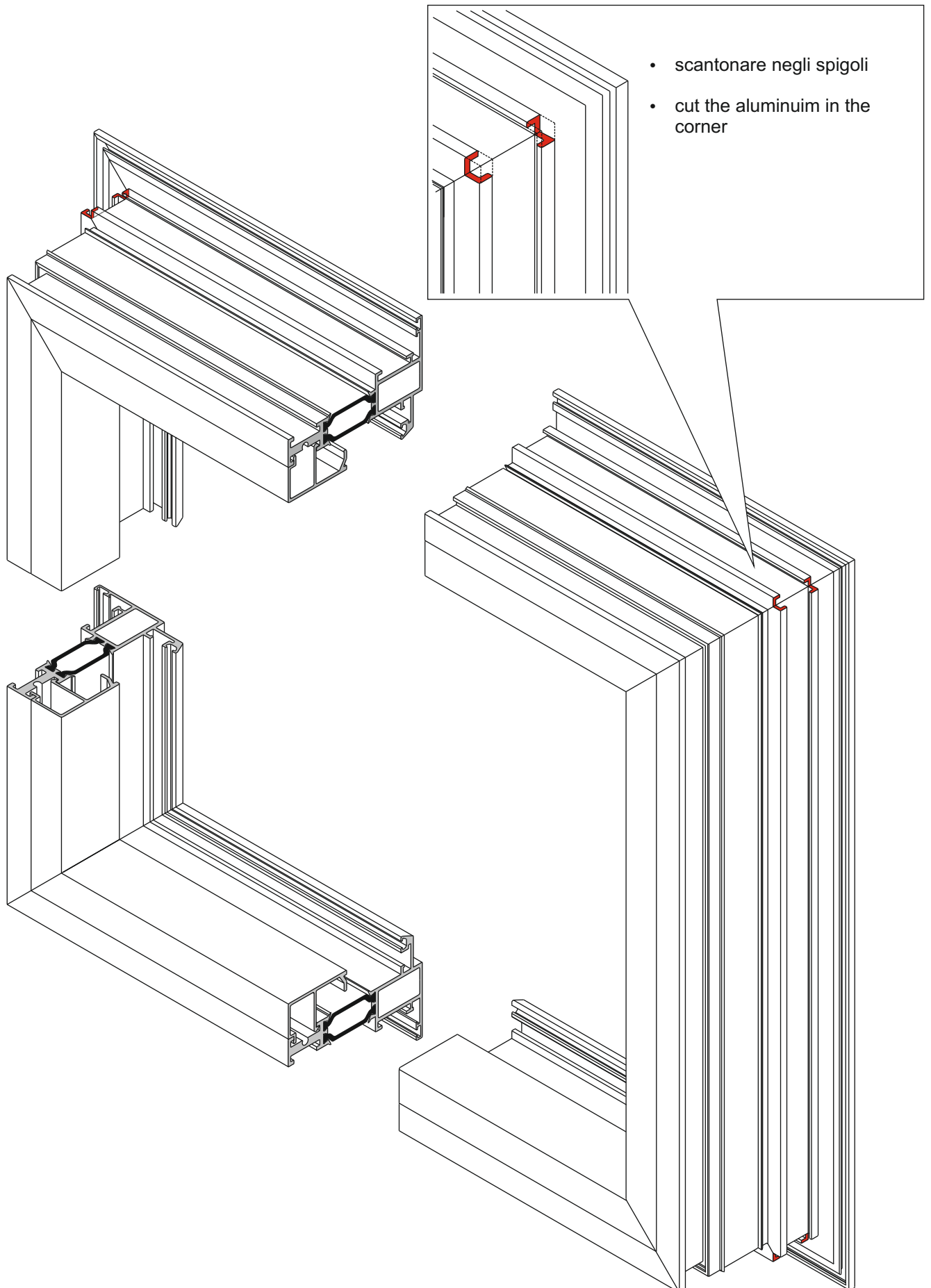

DIMA DI FORATURA PER TELAIO DRILLING JIG FOR FIXED FRAME

I

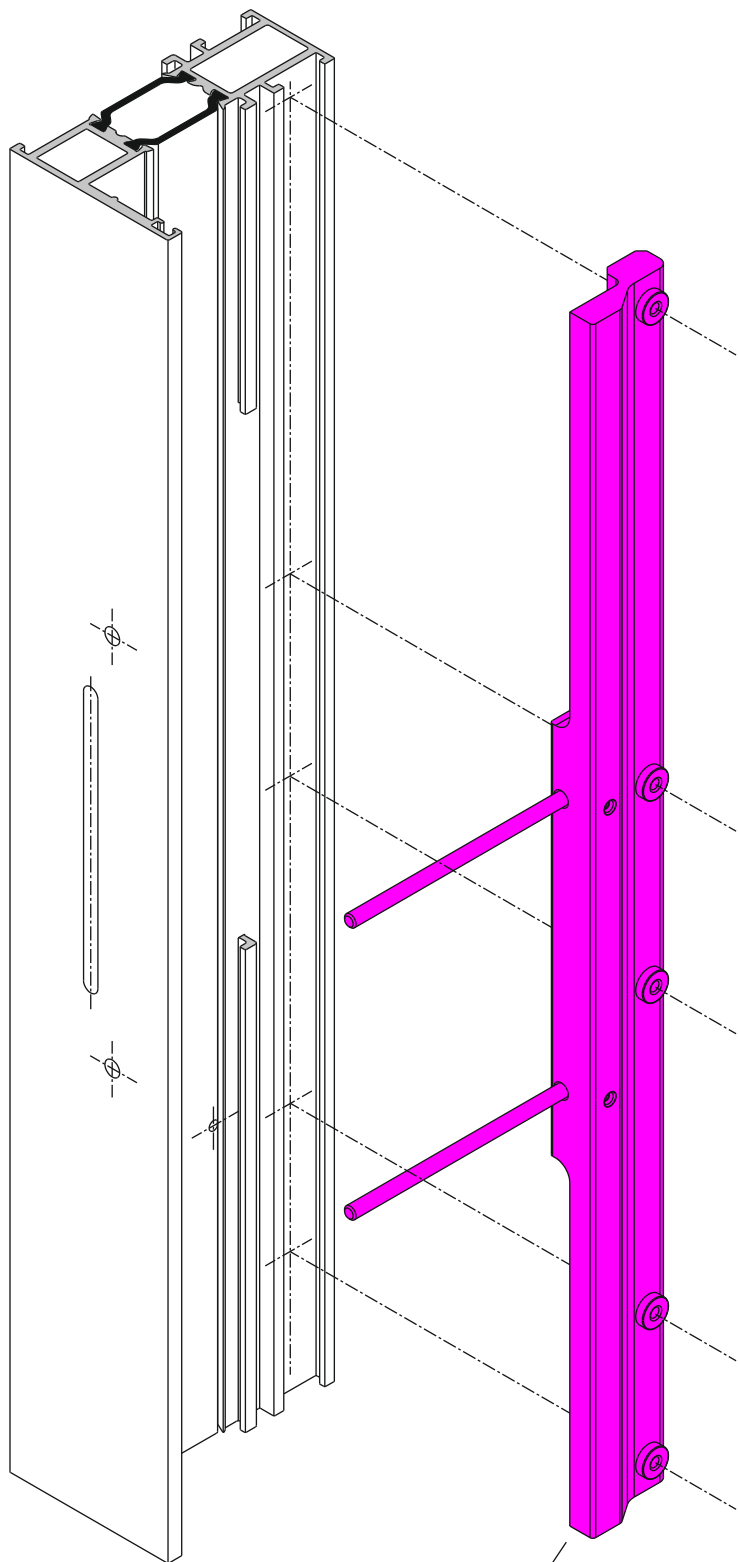

Art.:1208.950R

II

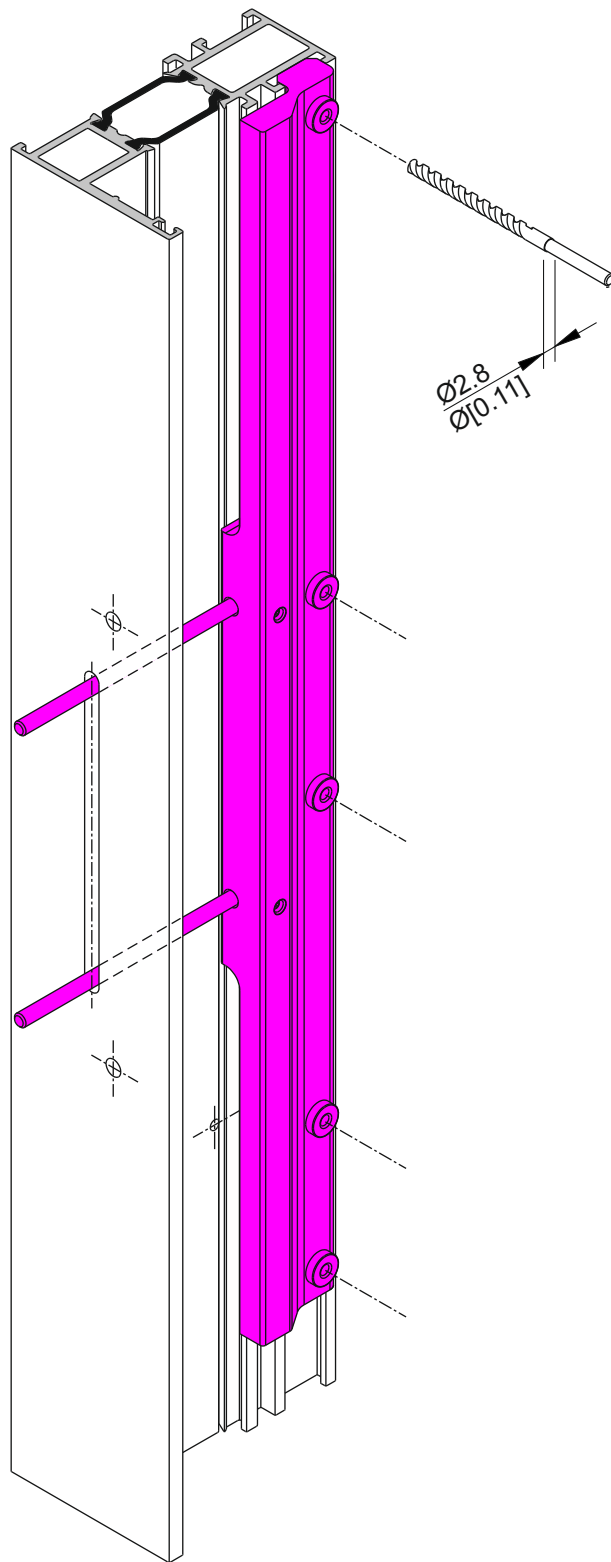

MONTAGGIO CARIGLIONE HANDLE FITTING

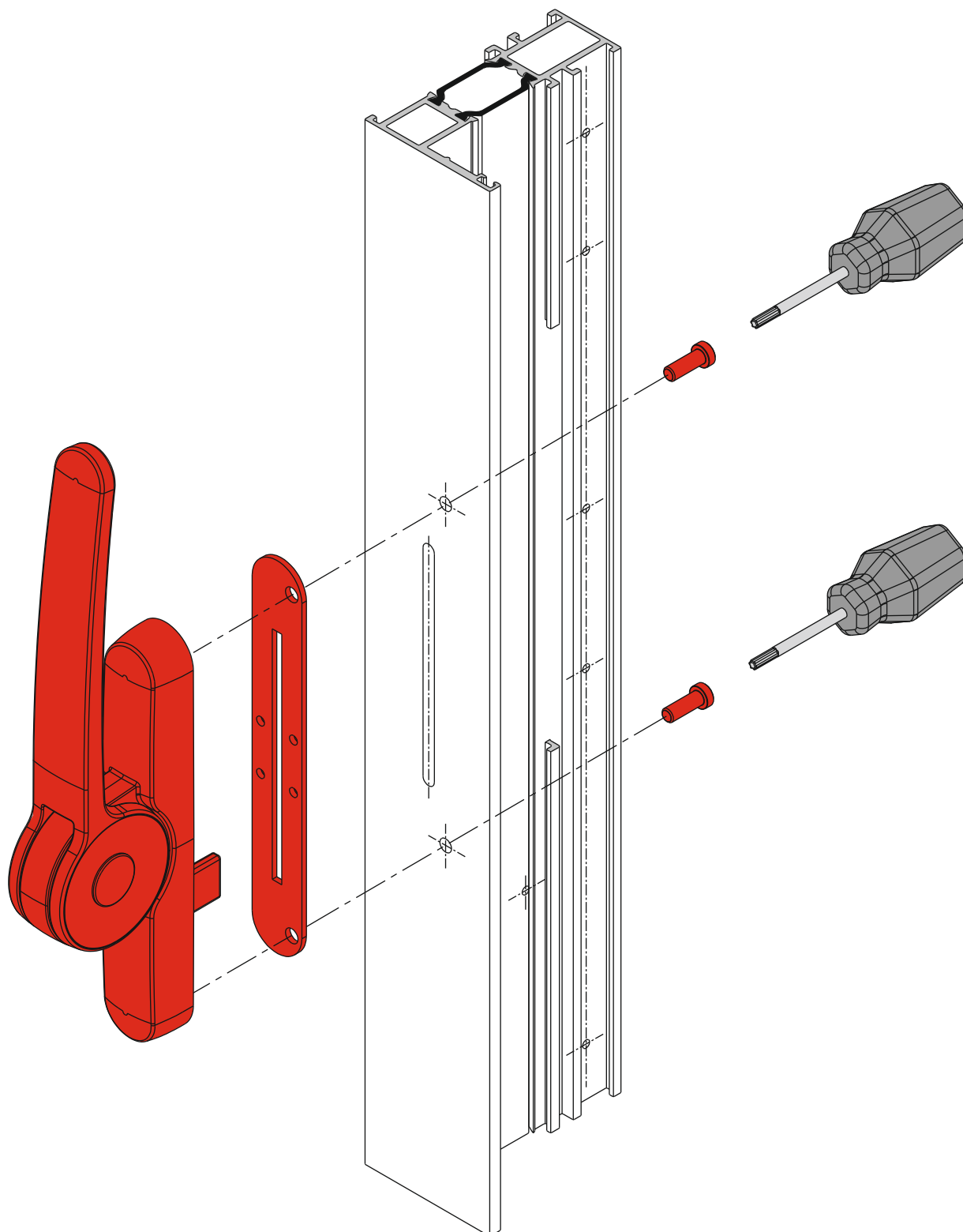

MONTAGGIO MECCANISMO DI MOVIMENTAZIONE FITTING MOVEMENT MECHANISM

I

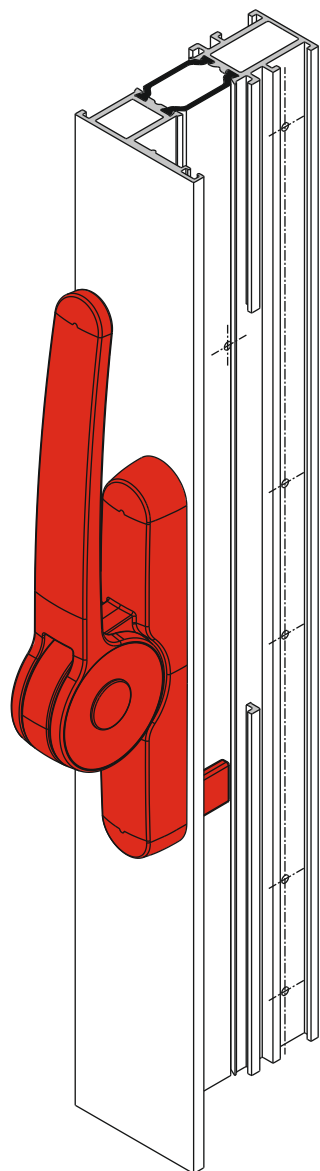

II

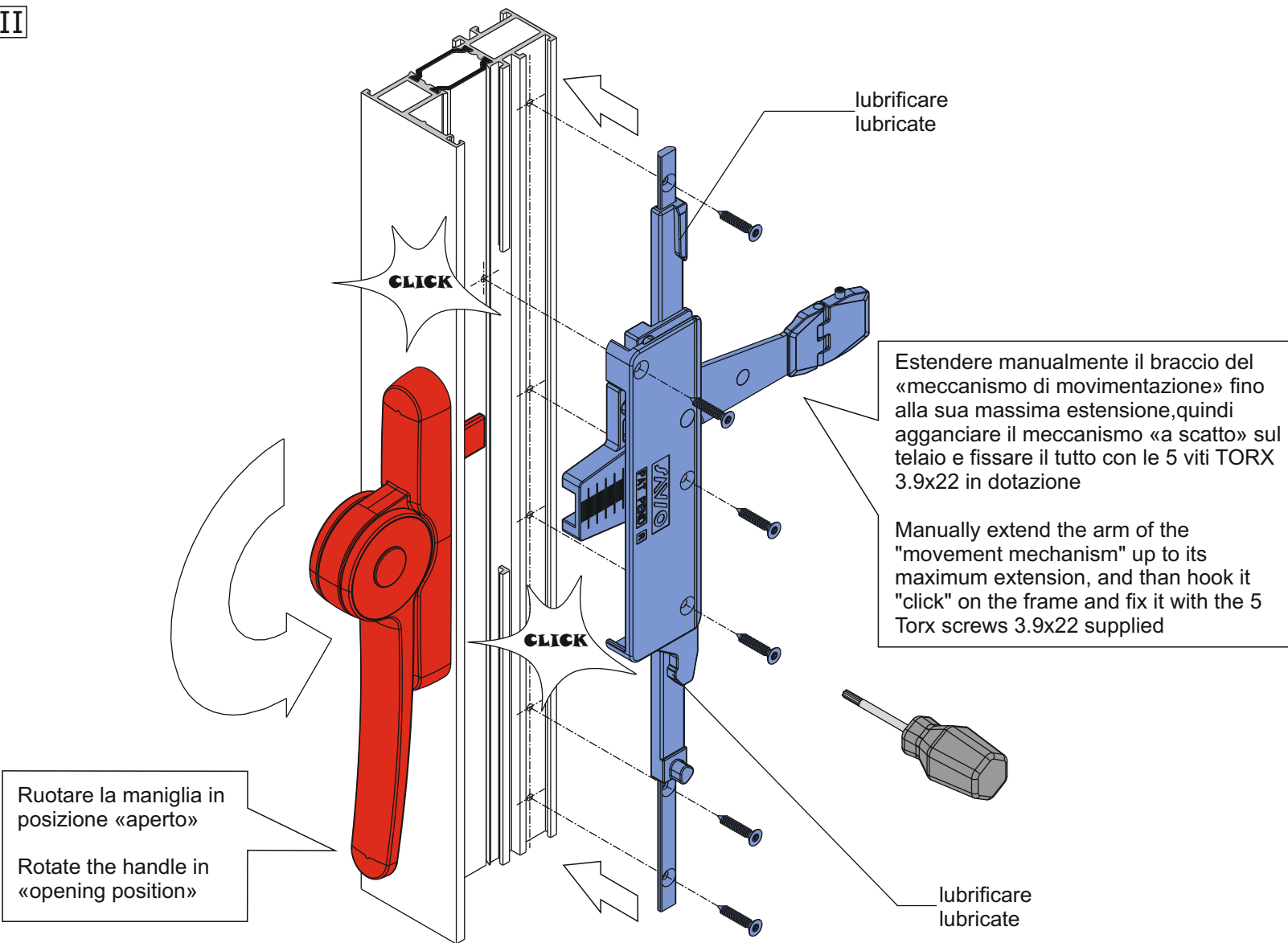

POSIZIONAMENTO ACCESSORI SU ANTA ACCESSORIES POSITIONING ON SASH

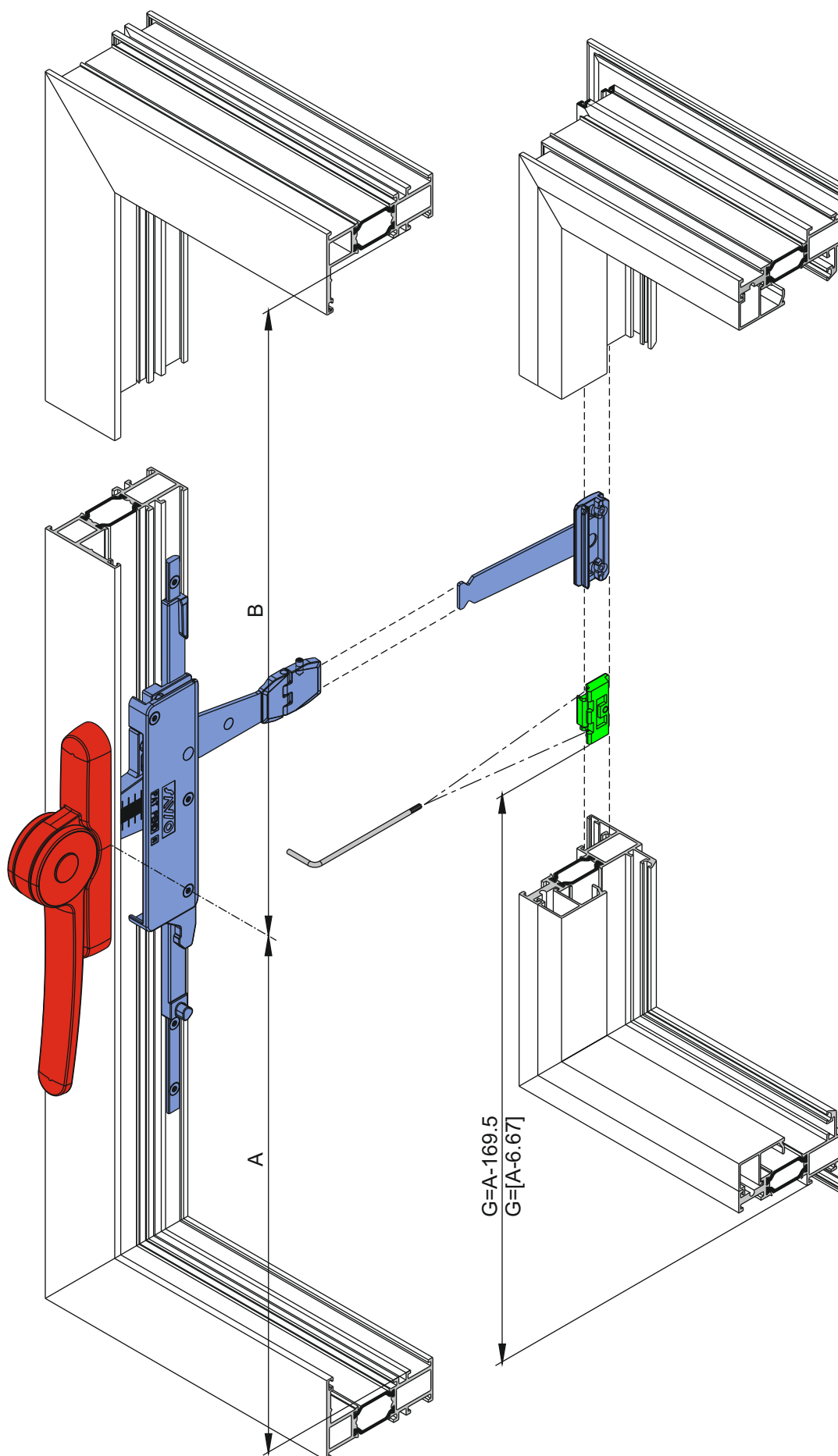

COLLEGAMENTO ANTA-TELAIO FRAME-SASH CONNECTION

I

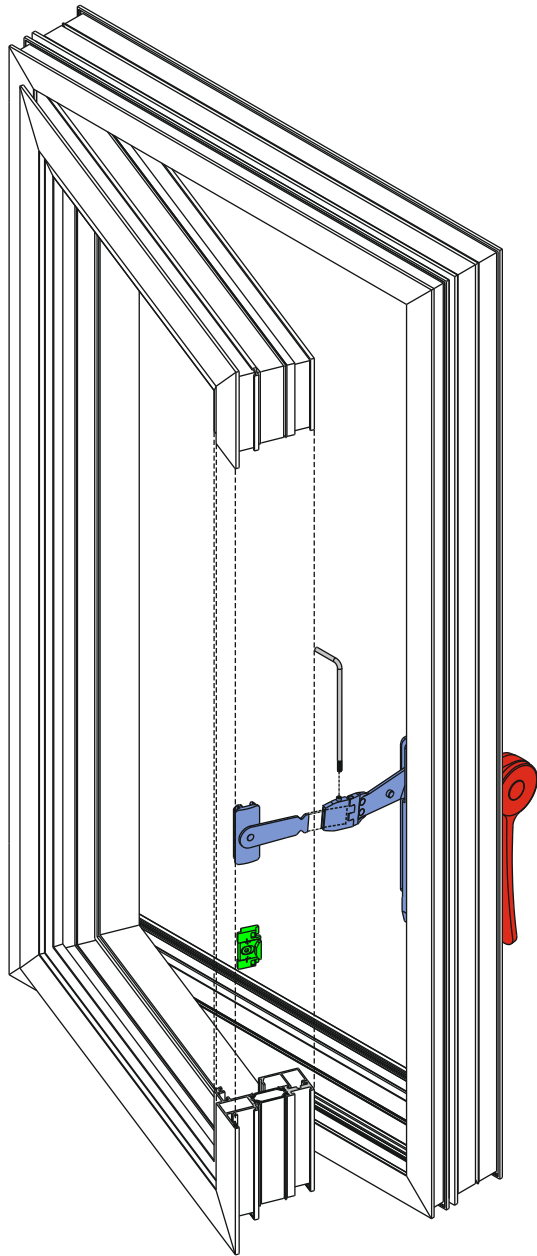

II

