

# ARIANNA



## NUOVA GAMMA DI CREMONESI, MANIGLIE E MARTELLINE

Nuovo design con forme più marcate  
Completezza di gamma  
Durevoli nel tempo  
Robuste e fluide

**AV SAVIO**

# ARIANNA.



# LA BELLEZZA A PORTATA DI MANO

Se il mercato oggi giorno richiede forme più marcate, linee più aggressive, un look-and-feel più innovativo, arriva puntuale la risposta di Savio con la nuova gamma ARIANNA di maniglie, cremonesi e martelline: affidabili, sicure, facili da montare, comode da impugnare, robuste.

Nuova gamma ARIANNA: maniglia, cremonese per anta e per anta-ribalta, martelline per tutte le applicazioni. Chiusura perfetta grazie alla corsa di 19 millimetri (anta-ribalta) e di 15 millimetri (anta).

ARIANNA è disponibile in più finiture. Una più bella dell'altra.

Il nuovo design di ARIANNA rinnova e potenzia gli stessi plus tradizionali di MANON: affidabilità, sicurezza e facilità di montaggio, oltre a raffinatezza e robustezza.

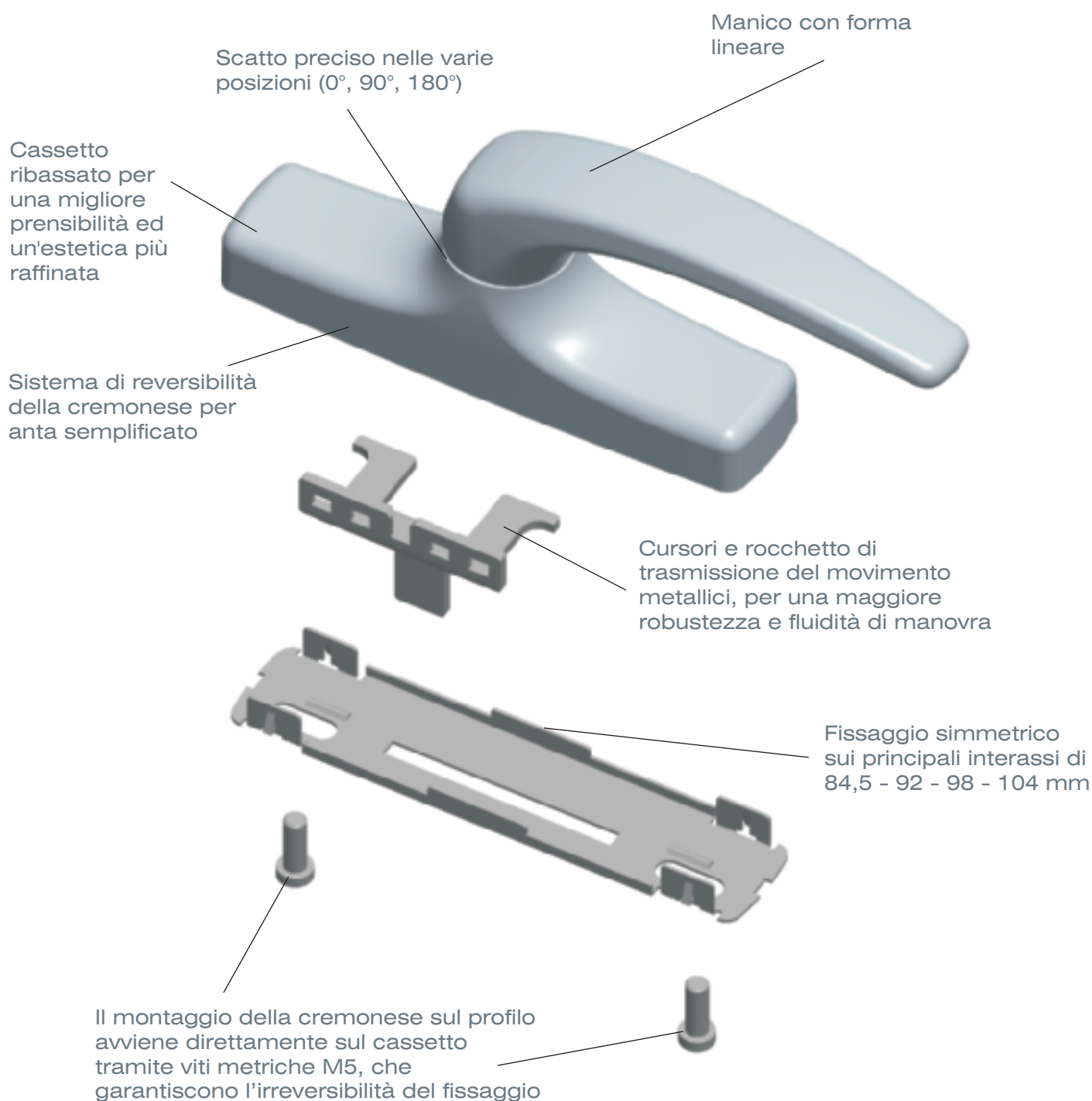

## Gamma di cremonesi per anta e per anta-ribalta

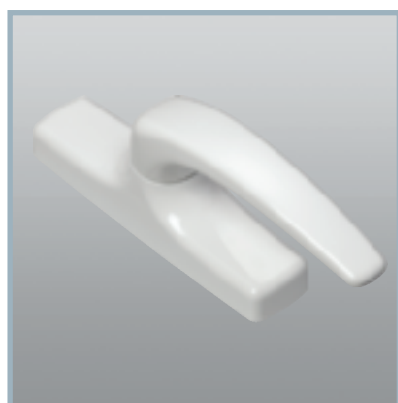

Articolo	Descrizione	Pz.	Finiture
865.1	ARIANNA (brevettato) Cremonese <b>per anta</b> in zama, interassi mm 84.5-98, 2 viti TCEI M5x14 in acciaio inox. Finiture PVD X, PVD H confezione 5 pz.	20	
865.2	ARIANNA come 865.1 ma interassi mm 92-104.	20	1013, 1015, 8017, 8019, 9001, 9005, 9010, B.SA, BL10, BR5, BR801, GR217, GREY, PVD H, PVD X, SILV
868.1	ARIANNA (brevettato) Cremonese <b>per anta-ribalta</b> in zama, interassi mm 84.5-98, 2 viti TCEI M5x14 in acciaio inox. Finiture PVD X, PVD H confezione 5 pz.	5	
868.2	ARIANNA come 868.1 ma interassi mm 92-104.	5	



Articolo	Descrizione	Pz.	Finiture
865.753	ARIANNA (brevettato) Cremonese <b>per anta</b> in zama, con cilindro di sicurezza (chiavi uguali), interassi mm 84.5-98, 2 viti TCEI M5x14 in acciaio inox. Finiture PVD X, PVD H confezione 5 pz.	10	
865.754	ARIANNA come 865.753 ma interassi mm 92-104.	10	1013, 1015, 8017, 8019, 9001, 9005, 9010, B.SA, BL10, BR5, BR801, GR217, GREY, PVD H, PVD X, SILV
868.753	ARIANNA come 865.753 ma per <b>anta-ribalta</b> .	5	
868.754	ARIANNA come 868.753 ma interassi mm 92-104.	5	

## Gamma di martelline e maniglie



Articolo	Descrizione	Pz.	Finiture
866.3/7	ARIANNA (brevettato) Martellina a scatto con manico in zama, interasse 43 mm, albero quadro di 7 mm con sporgenza di 24.5 mm e 2 viti TC M5x35 in acciaio zincato.	5	
866.4/7	ARIANNA (brevettato) Martellina a scatto con manico in zama, interasse 43 mm, albero quadro di 7 mm con sporgenza di 52 mm e 2 viti TC M5x60 in acciaio zincato.	5	1013, 8019, 9005, 9010, BL10, BR5, C, GR217, PVD H, PVD X, SILV



Articolo	Descrizione	Pz.	Finiture
866.31	ARIANNA (brevettato) Maniglia doppia ambidestra con molla premontata, in zama, albero quadro 8x120 mm e 4 viti TC Ø 4,2x19 in acciaio zincato (finiture PVD H e PVD X confezione da 4 pz.).	10	1013, 8019, 9005, 9010, BL10, BR5, C, GR217, PVD H, PVD X, SILV

## Gamma di meccanismi mono e bi-direzionali



Articolo	Descrizione	Pz.	Finiture
1200/7	MONO Movimento monodirezionale con entrata di 8 mm per anta-ribalta, in zama zincata nera, foro quadro di 7 mm, boccole di maggiorazione Ø 6-Ø 8 mm in nylon.	5	

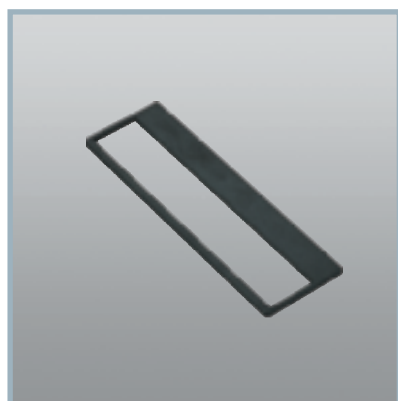

Articolo	Descrizione	Pz.	Finiture
1200.801	Spessore di 2 mm in nylon (da utilizzare con gli articoli 1200/1201 per l'applicazione sul profilo R 40 e NEW TEC).	40	



Articolo	Descrizione	Pz.	Finiture
1201/7	DUO Movimento bidirezionale per anta con entrata di 8 mm, in zama zincata nera, foro quadro di 7 mm, boccole di maggiorazione Ø 6-Ø 8 mm in nylon.	20	



Articolo	Descrizione	Pz.	Finiture
1202/7	Movimento bidirezionale con entrata da 22 mm, in zama zincata bianca, foro quadro di 7 mm, 2 boccole di maggiorazione Ø 6-Ø 8 mm in nylon.	20	

## Gamma di meccanismi mono e bi-direzionali



Articolo	Descrizione	Pz.	Finiture
1203/7	MONO Movimento monodirezionale con entrata di 16 mm per anta-ribalta, in zama zincata nera, foro quadro di 7 mm, boccole di maggiorazione Ø 6-Ø 8 mm in nylon.	5	



Articolo	Descrizione	Pz.	Finiture
1204/7	DUO Movimento bidirezionale con entrata di 16 mm per anta in zama zincata nera, foro quadro di 7 mm, boccole di maggiorazione Ø 6-Ø 8 mm in nylon.	10	



Articolo	Descrizione	Pz.	Finiture
1210/7	MONO Movimento monodirezionale per RIBANTA 5 con entrata di 14,5 mm, in zama zincata bianca, foro quadro di 7 mm.	5	



Articolo	Descrizione	Pz.	Finiture
1211/7	DUO Movimento bidirezionale per anta con entrata di 14,5 mm, in zama zincata bianca, foro quadro di 7 mm.	20	

## Accessori per cremonesi



Articolo	Descrizione	Pz.	Finiture
865.801	Mensola di rinforzo per cremonesi in zama zincata nera, 1 vite TSEI M5x18 in acciaio inox.	200	

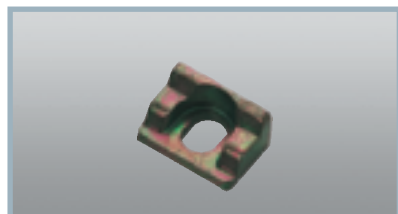

Articolo	Descrizione	Pz.	Finiture
870.802	Staffa di rinforzo in zama zincata per profili a Camera Unificata e NC International.	200	
870.802W	Come 870.802 ma zincata bianca.	200	

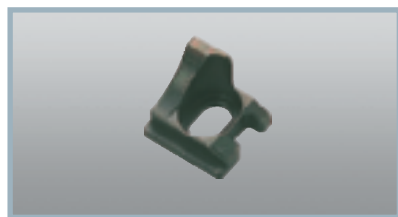

Articolo	Descrizione	Pz.	Finiture
870.803	Staffa di rinforzo in metallo pressofuso per profili R 40/50 e NEW TEC.	200	

## Accessori per maniglie



Articolo	Descrizione	Pz.	Finiture
874.804	Mostrina in metallo pressofuso per cilindro sagomato, 2 viti TC Ø 3,5x13 in acciaio zincato.	20	1013, 1015, 10135, 7047, 8017, 8019, 9001, 9005, 9010, 9016, B.SA, BL10, BR5, BW21, C, GR217, GREY, PVD H, PVD X, SILV, WT005



Articolo	Descrizione	Pz.	Finiture
874.897	Kit di fissaggio per maniglia composto da 2 viti M5x124 zincate bianche e 2 dadi quadri M5 zincati bianchi.	40	



Articolo	Descrizione	Pz.	Finiture
874.898	Albero quadro 8x160 mm in acciaio zincato bianco per porte con spessore da 55 mm a 100 mm.	50	
874.899	Albero quadro 8x140 mm in acciaio zincato per porte con spessore da 55 mm a 70 mm.	50	



Gamma di cremonesi per anta e per anta-ribalta

865.1 - 865.2

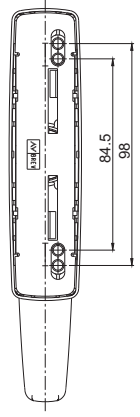
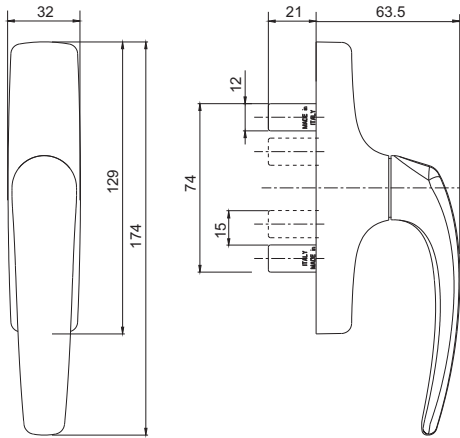

865.1

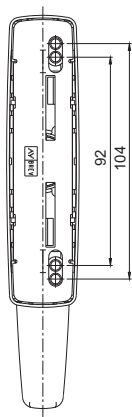
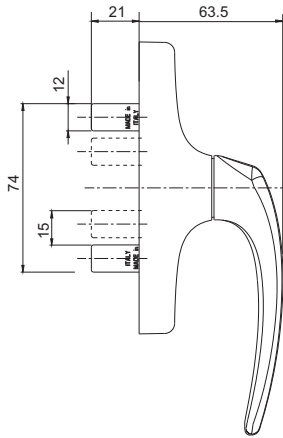

865.2

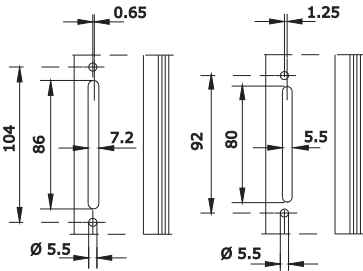
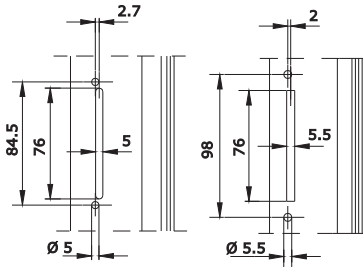

865.753 - 865.754

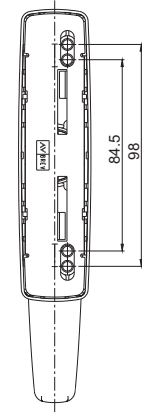
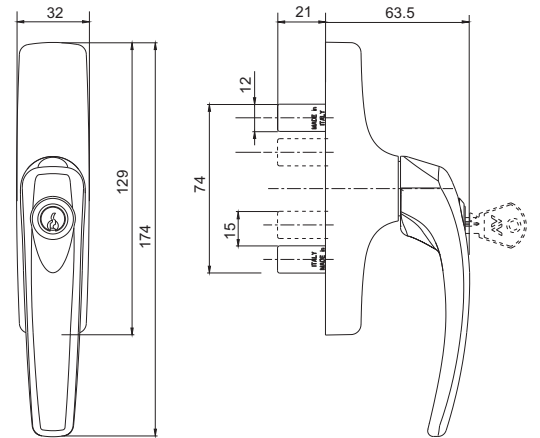

865.753

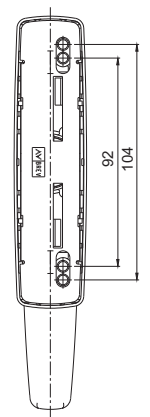
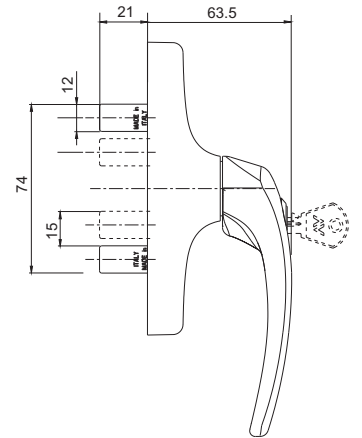

865.754

868.1 - 868.2

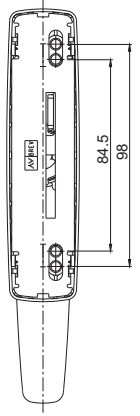
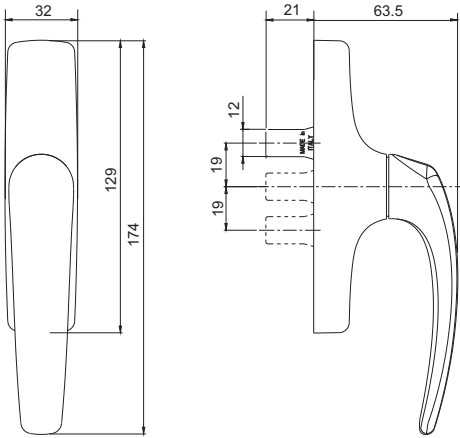

868.1

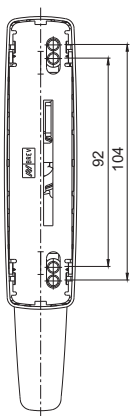
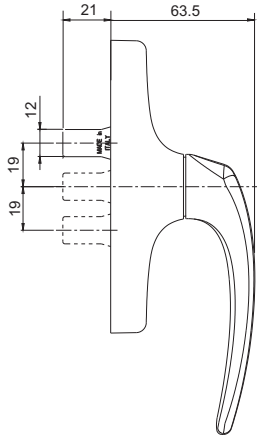

868.2

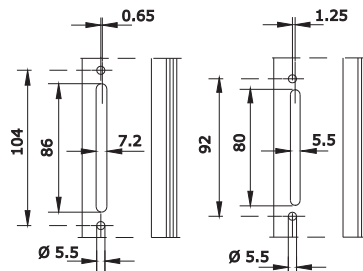
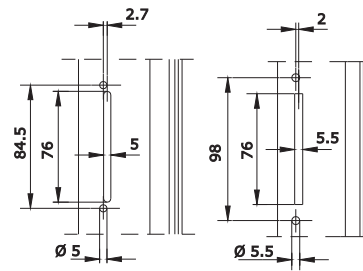

868.753 - 868.754

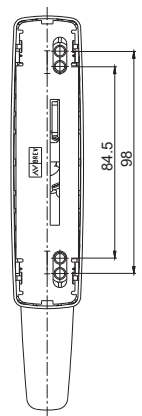
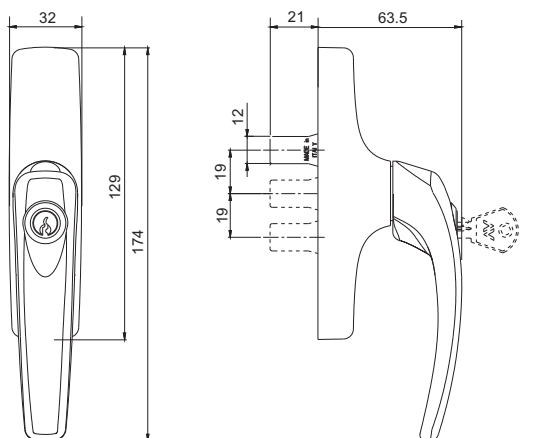

868.753

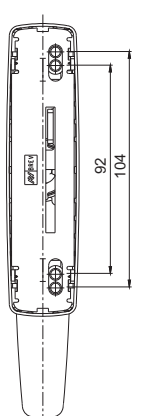
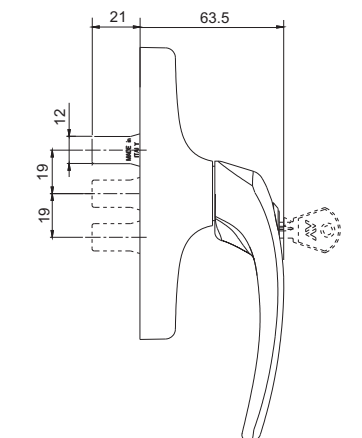

868.754

## Gamma di martelline e maniglie

866.3/7

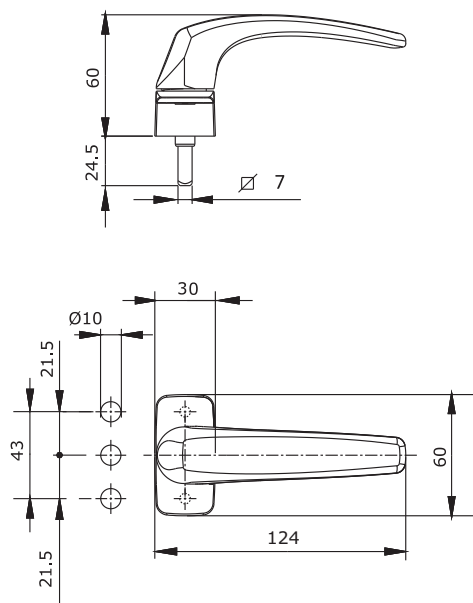

866.4/7

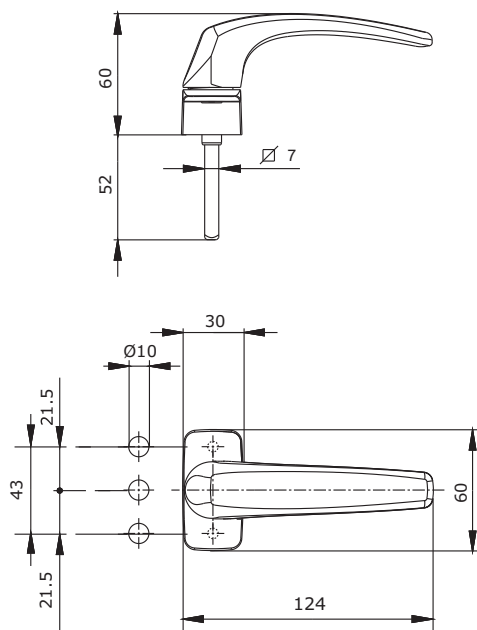

866.31

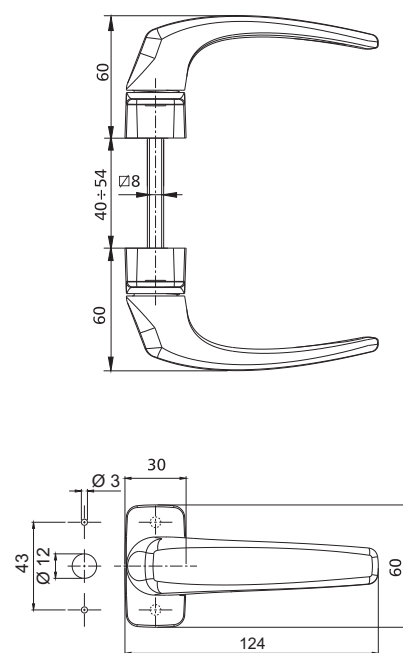

## Gamma di meccanismi mono e bi-direzionali

1200/7

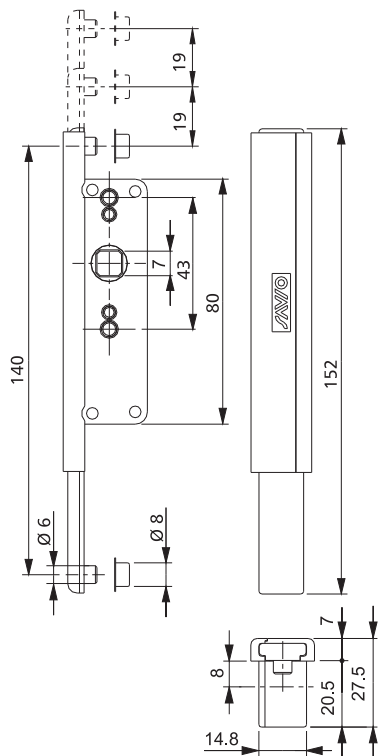

1200.801

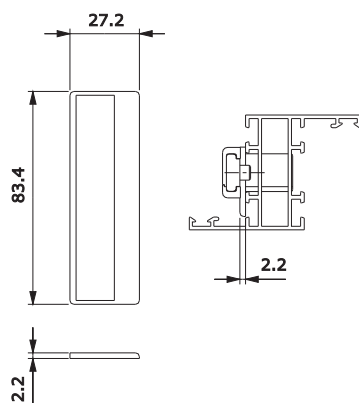

1201/7

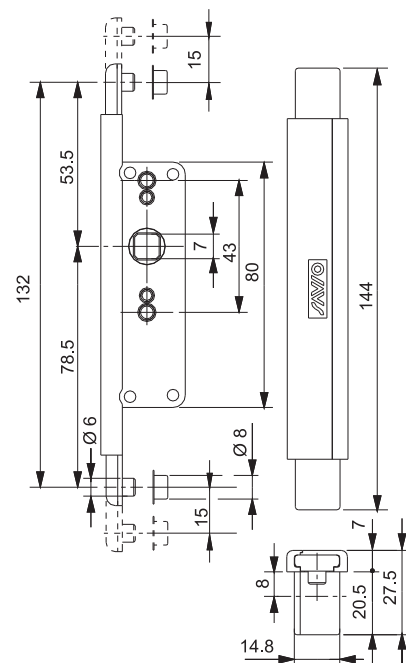

Gamma di meccanismi mono e bi-direzionali

1202/7

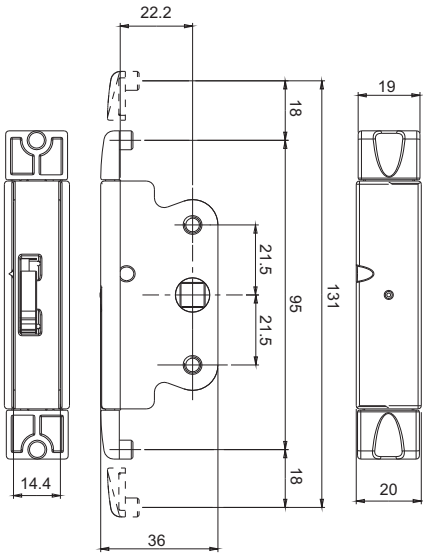

1203/7

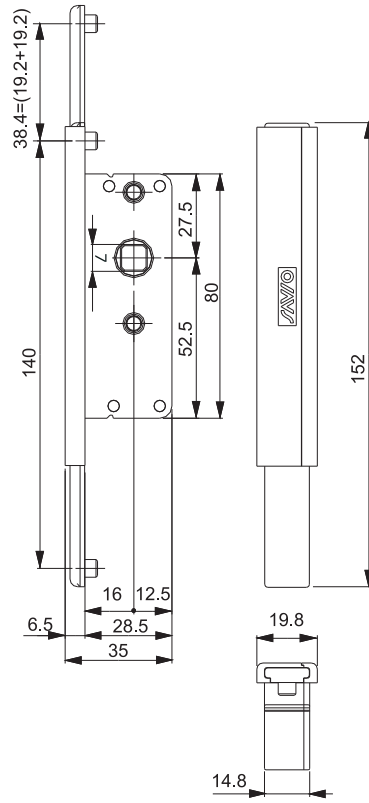

1204/7

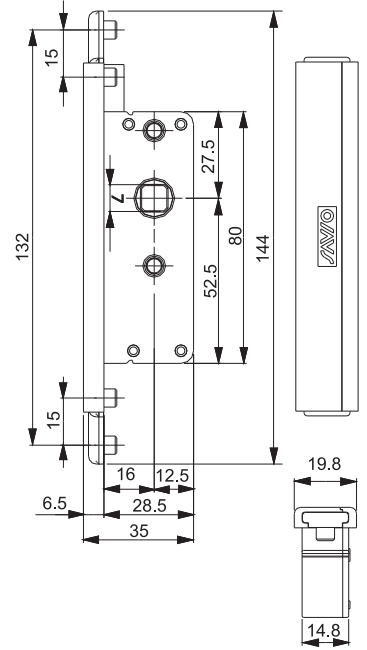

1210/7

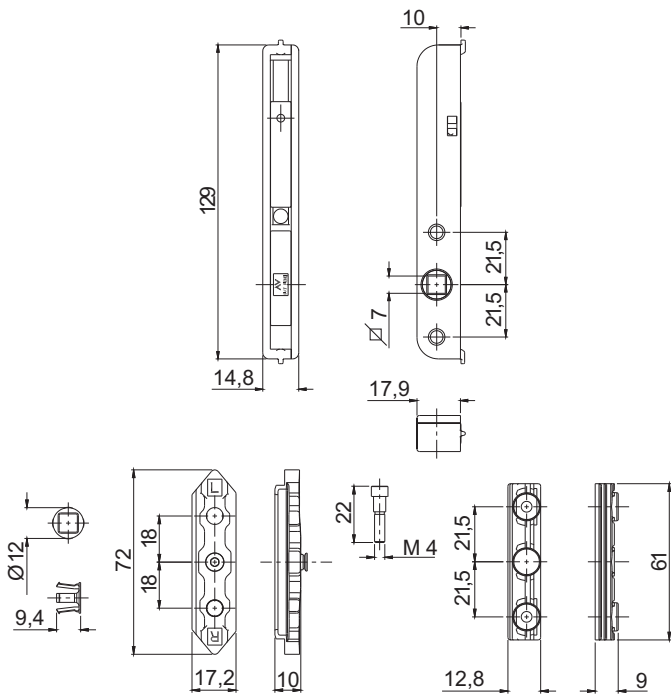

1211/7

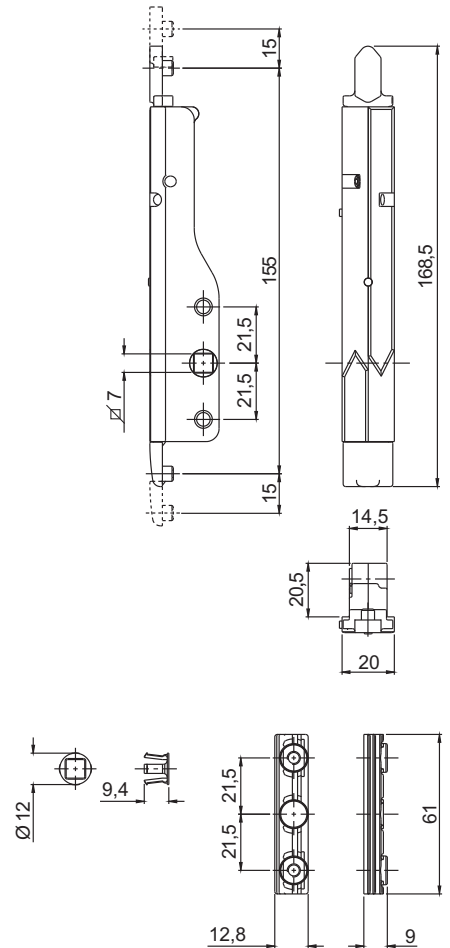

## Accessori per cremonesi e maniglie

865.801

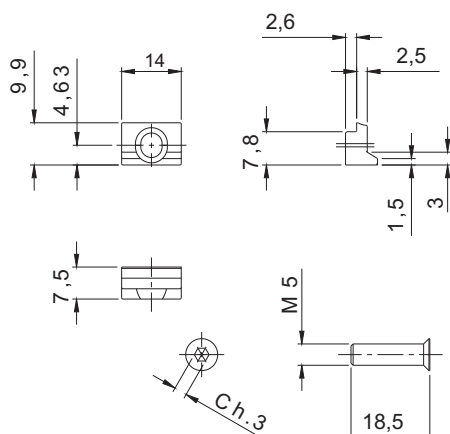

870.802 - 870.802W

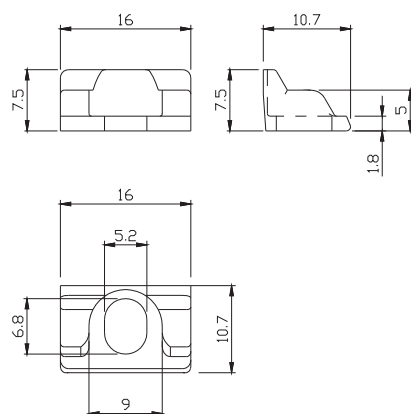

870.803

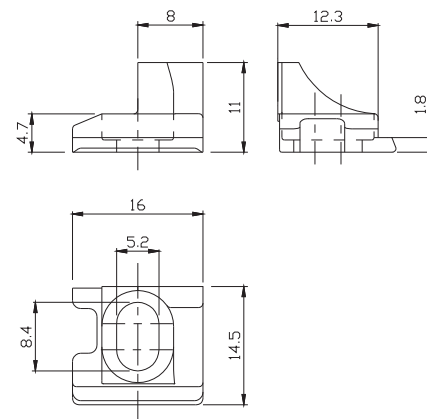

874.804

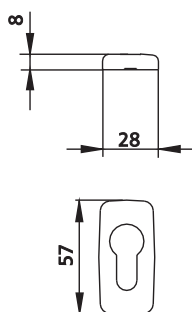

874.897

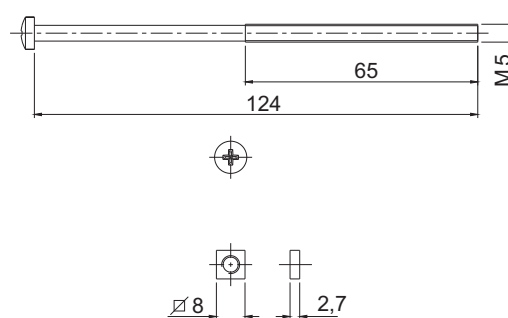

874.898

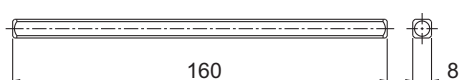

874.899

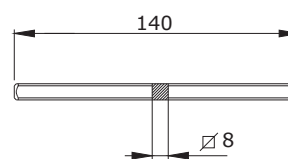

Savio S.p.A.

Via Torino, 25 (s.s. 25) - 10050 Chiusa S. Michele (TO)  
 tel. +39 011 964 3464 - fax +39 011 964 3474  
 www.savio.it - savio@savio.it